

VOLVO PENTA INBOARD DIESEL

D12-300

6-cylinder, 4-stroke, direct-injected, turbocharged marine diesel engine with aftercooler – crankshaft power* 216 kW (294 hp)

* Power rating – see Technical Data

Excellent reliability and economy

The D12-300 marine diesel engine is specially designed and developed for installations in heavy duty commercial displacement craft, featuring the latest advanced diesel technology.

To meet the tough and demanding reliability and durability demands from operators and fleet owners, the D12-300 has been tried and tested in the world's toughest and most extensive test program. 40 man-years behind the design and 25 man-years in tests, which equals eight times around the world, ensures excellent reliability and durability.

Excellent drivability is assured with high low-end and a rich torque curve matched to the power outputs for fast and immediate response.

Low fuel consumption for long operational range and low operational cost and emission levels is assured with:

- Electronic Unit Injectors
- 4-valve technology
- Electronically controlled injection timing
- High pressure 5-hole injector nozzles
- Electronic governing – EMS

This technology combined optimizes engine performance and efficiency, ensures efficient combustion by injecting the right quantity of fuel at the right time, which minimizes quantity of unburned fuel, reducing fuel consumption and exhaust emission levels. The Volvo Penta D12-300 fuel system is designed to give full output regardless of fuel temperature.

This technology in combination with the Electronic Vessel Control, EVC, protects the engine from major breakdowns, which further enhances the high reliability and long service life for low operational costs.

High quality

The D12-300 is built in the world's most highly automated diesel engine factory line with a totally robotic machining and assembly line with computer controlled audit checks, which ensures the highest quality level.

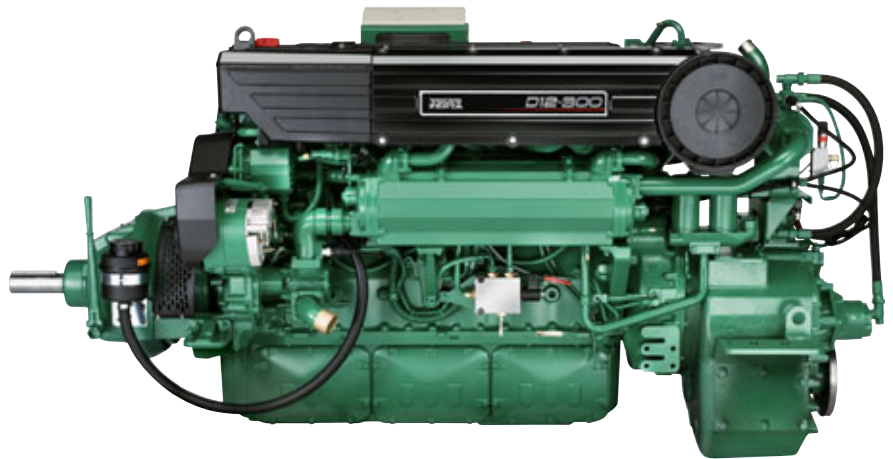

Electronic Vessel Control (EVC/EC)

EVC Electronic Vessel Control is the next generation of distributed control systems for marine applications. EVC adds features like electrical shift and throttle, synchronization, a new generation of instrumentation and much more. The electrical control levers are operated smoothly and precisely, with little force. Automatic twin engine synchronization reduces noise and vibrations levels, and increases service life of engine.

This, in combination with the well-balanced D12-300 in-line six cylinder engine with powerfully dimensioned crankshaft bearings and vibration damper on camshaft, ensures smooth, vibration-free operation with low noise levels.

Low exhaust emission levels

The D12-300 advanced diesel technology greatly contributes to more efficient combustion with higher power and reduced noxious exhaust emissions.

The D12-300 is certified according to IMO and CCNR.

Easy installation

The D12-300 together with EVC gives a time-saving and reliable installation, as it is a complete delivered compact and tailor-made propulsion system from one single supplier.

Plug-in water-protected harnesses and connectors, compact dimensions, and the EVC system ensures an easy, simple and time-saving installation.

Ease of service and maintenance

The EVC system features a self-diagnostic facility. Easily accessible service and maintenance points contributes to the ease of service of the engine.

Worldwide service support in more than 100 countries

The Volvo Penta parts and service dealer network is a truly international operation with authorized service dealers around the world. These service centers offer Genuine Volvo Penta parts as well as skilled personnel to ensure the best possible service. Continuous and thorough product and service training ensures that Volvo Penta products are well supported.

D12-300 – a true marine engine from a true marine engine company

The D12-300 is a true marine engine, as it is developed by a true marine company with the best there is to be found in marine experience and know-how, and built and assembled with the best production method there is to be found in the world.

The D12-300 delivers excellent reliability, economy and durability, in combination with the highest level of quality.

**VOLVO
PENTA**

D12-300

Technical Data

Engine designation**D12D MH**
 No. of cylinders and configuration in-line 6
 Method of operation4-stroke,
 direct-injected, turbocharged
 diesel engine with aftercooler
 Bore, mm (in.)131 (5.16)
 Stroke, mm (in.)150 (5.91)
 Displacement, l (in³)12.13 (740.2)
 Compression ratio 17.5:1
 Dry weight, kg (lb).....1400 (3086)
 Dry weight with reverse gear
 MG5114SC, kg (lb)1603 (3534)
 MG5114DC, kg (lb)1768 (3898)
 Crankshaft power,
 kW (hp) @ 1800 rpm216 (294)
 Max. torque,
 Nm (lb.ft.) @ 1000 rpm1461 (1078)
 Recommended fuel to
 conform to ASTM-D975 1-D & 2-D,
 EN 590 or JIS KK 2204
 Specific fuel consumption,
 g/kWh (lb/hph) @ 1800 rpm 209 (0.338)
 Technical data according to ISO 3046 Fuel Stop Power and ISO
 8665. With fuel having an LHV of 42700 kJ/kg and density of
 840 g/liter at 15°C (60°F). Merchant fuel may differ from this
 specification which will influence engine power output and fuel
 consumption.
 Rating: 1
 The engine is certified according to IMO and River Rhine (CCNR).

- Each cylinder features cross-flow inlet and exhaust ducts
- Gallery oil-cooled forged aluminum pistons
- Three piston rings

Lubrication system

- Integrated oil cooler in cylinder block
- Twin full flow oil filter of spin-on type and by-pass filter

Fuel system

- Six Electronic Unit Injectors, one per cylinder, vertically positioned at the center in between the four valves
- Gear-driven fuel pump, driven by timing gear
- Electronically controlled central processing system (EMS – Engine Management System)
- Electronically controlled injection timing
- 5-hole high pressure injector nozzles
- Single fine fuel filter of spin-on type, with water separator

Turbocharger

- Freshwater-cooled turbo charger

Cooling system

- Freshwater-cooled charge air cooler
- Gear-driven coolant pumps
- Tubular heat exchanger or single-circuit keel cooling

Electrical system

- 24V electrical system, 24V/60A alternator

Reverse gear

- MG5114SC/DC-E, electrically shifted

Optional equipment

Contact your Volvo Penta representative.

Not all models, standard equipment and accessories are available in all countries. All specifications are subject to change without notice.

The engine illustrated may not be entirely identical to production standard engines.

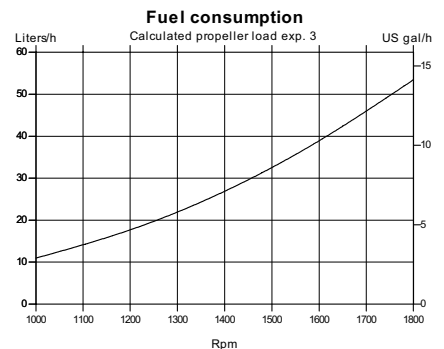
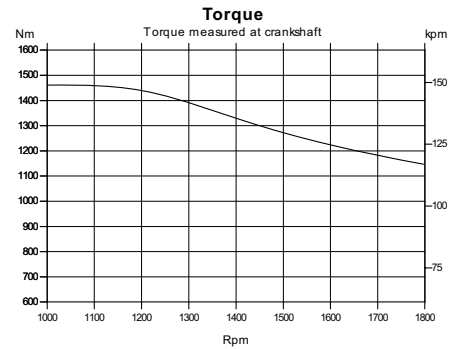
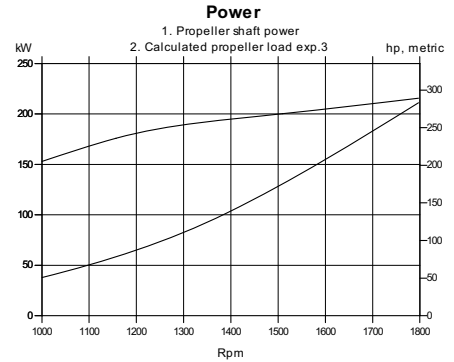

Technical description:

Engine and block

- Cylinder block and cylinder head made of cast-iron
- One piece cylinder head
- Replaceable wet cylinder liners and valve seats/guides
- Drop forged crankshaft with induction hardened bearing surfaces and fillets with seven main bearings
- Four valve per cylinder layout with overhead camshaft

Dimensions D12-300 with MG5114SC-E

Not for installation

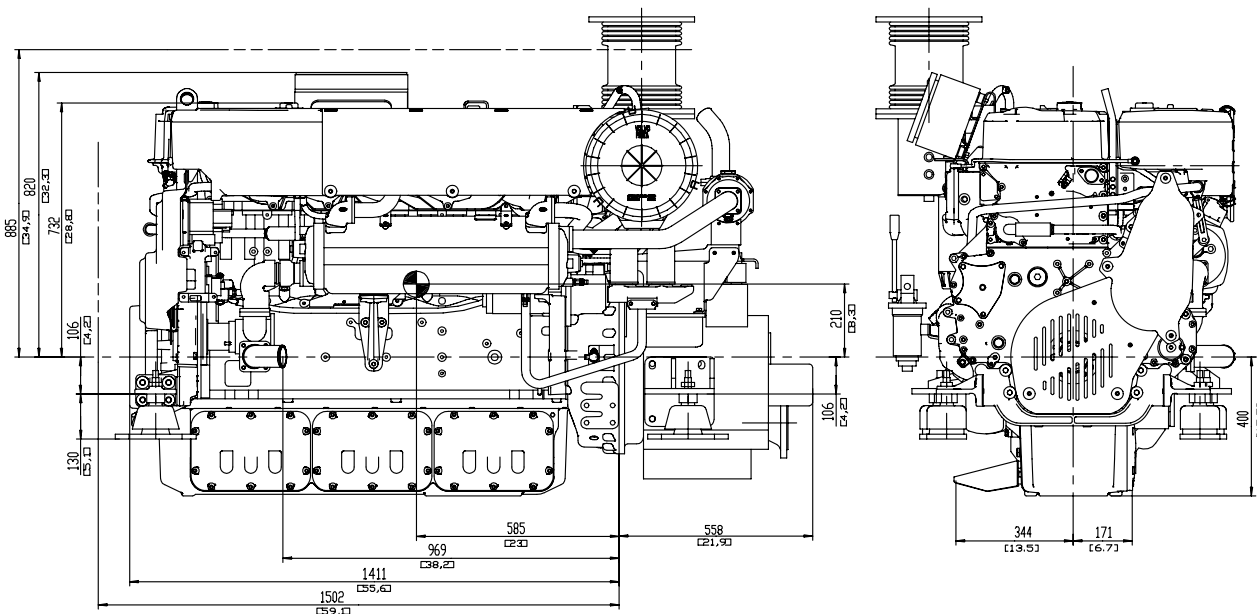

AB Volvo Penta
 SE-405 08 Göteborg, Sweden
 www.volvopenta.com