

# VOLVO PENTA MARINE DIESEL

# D25A MS

440 – 485 kW ( 598 – 660 hp) crankshaft power

## Powerful and reliable engine for demanding operation in commercial applications

The Volvo Penta D25A MS engine is designed to meet the most demanding requirements, such as marine main propulsion or marine generator drive. Its compactness and durability applies the most advanced technologies and engineering know-how; all this to benefit the operator.

The Volvo Penta D25A MS diesel engine is built to the highest quality standards recognized by all the major marine classification societies, such as Germanischer Lloyds, Norske Veritas etc. as well as the national Shipping Inspections.

Volvo Penta is continuously making intensive research work on the marine application of the engine to produce an engine with a compact design, which gives many advantages, such as low running costs in relation to high output.

An optimal combination of combustion chambers, fuel injection system, and effective turbocharger and charge air cooling system, provide an excellent fuel consumption over the whole range of engine speeds, through which the engine is economical in operation.

Maintenance is very easy, as supplementary equipment such as fuel injection pump, governor, water pump and turbocharger do not need any separate lubrication. The cylinder heads are individually divided by cylinder, and the engine has large inspection covers in crankcase and oilpan.

As the dimensions of the D25A MS engine are kept as small as possible,



it takes up surprisingly little space. This asset will be subscribed wholeheartedly by the person who is in charge of the engine room. An engine room equipped with this engine is a well-ordered engine room.

## Warranty and Service

All Volvo Penta marine engines come with the additional benefit and security of the Cost Control Program, a unique system of operator support and financial control – from installation to after-sales service.

The optional international limited Volvo Penta three-year warranty provides the owner peace of mind.

Qualified Volvo Penta dealers stand by for service and support in more than 100 countries all over the world.

**VOLVO  
PENTA**

# D25A MS

## Technical Data

|  |   |
|--|---|
| Engine designation   | D25A MS   |
| No. of cylinders and configuration                                       | in-line 6   |
| Method of operation  | 4-stroke, direct-injected, turbocharged diesel engine with after cooler |
| Bore, mm   | 170   |
| Stroke, mm   | 180   |
| Displacement, l  | 24.51   |
| Compression ratio  | 14:1  |
| Dry weight (HE), kg  | 3000  |
| Dry weight (KC), kg  | 2900  |
| Crankshaft power at calculated propeller load, Rating 1, kW(hp) 1600rpm  | 440 (598)   |
| Rating 2, kW(hp) 1650rpm   | 485 (660)   |
| Torque at calculated propeller load, Rating 1, Nm 1600 rpm               | 2627  |
| Rating 2, Nm 1650 rpm  | 2808  |
| Recommended fuel to conform to   | ASTM No. 2-D  |
| Specific fuel cons. at calculated propeller load, Rating1, g/kWh 1600rpm | 213   |
| Rating2, g/kWh 1650rpm   | 216   |

All data represent net performance including standard equipment as lube oil pump, water pump charging alternator, under the conditions of 100kPa barometric pressure, 25°C ambient temperature, 30% relative humidity and 32°C sea water temperature.

The propulsion engine with rating 1 power setting is exhaust emission certified for River Rhine.  
The engine type complies with IMO MARPOL 73/78 Annex VI exhaust emission standard. For detailed information contact Volvo Penta

Note! The engine illustrated may not be entirely identical to production standard engines.

## Standard Equipment:

### Engine

- Flywheel housing with connection acc. to SAE 0
- Flywheel (18")

### Lubrication system

- Fresh water cooled oil cooler
- Spin-on type oil filter with shift valve
- Spin-on type oil by-pass filter

### Fuel system

- Hydraulic governor
- Jacketed fuel pipes
- Spin-on type fuel filter (change-over type)

### Exhaust system

- Non-cooled turbocharger
- Air inlet filter/silencer

### Heat Exchanger cooled system (HE)

- For Seawater and central cooled installations
- Engine mounted tubular heat exchanger with integrated expansion tank

### Keel cooled cooling system (KC)

- For connection to one external cooler
- 1-circuit keel cooling system

### Electrical system

- Starter motor (DC 24V-7.5kW)
- Alternator (24V-35A)

### Other equipment

- Front P.T.O. pulley
- Front safety cover
- Standard tools

## Optional Equipment:

- Electrical system including wiring, senders, switches and terminal box mounted on engine
- 24V fuel shut-off valve, electrically operated
- Instrument panel for engine-room and wheel-house
- Raw-water pump
- Air starting system on request
- Oil drain pump
- Flexible exhaust hose for dry exhaust line
- Dry exhaust silencer
- Fuel filter/water separator with shift valve
- Classification under all the major marine classification societies
- Gearbox on request
- Spare parts

Contact Volvo Penta for further information. Not all models, standard equipment and accessories are available in all countries. All specifications are subject to change without notice. The engine illustrated may not be entirely identical to production standard engines.

### Marine Commercial Ratings

#### Rating 1 (R1, Heavy Duty Commercial)

This power rating is intended for commercial vessels with displacement hulls in heavy operation, unlimited number of running hours per year. Load and speed could be constant, and full power can be used without interruption.

#### Rating 2 (R2, Medium Duty Commercial)

This power rating is intended for commercial vessels with semiplaning or displacement hulls in cyclical operation, running hours less than 3000 h per year. Full power could be utilized maximum 4 h per 12 h operation period. Between full load operation periods, engine speed should be reduced at least 10% from the obtained full load engine speed.

## Crankshaft power D25A MS

Power measured at crankshaft

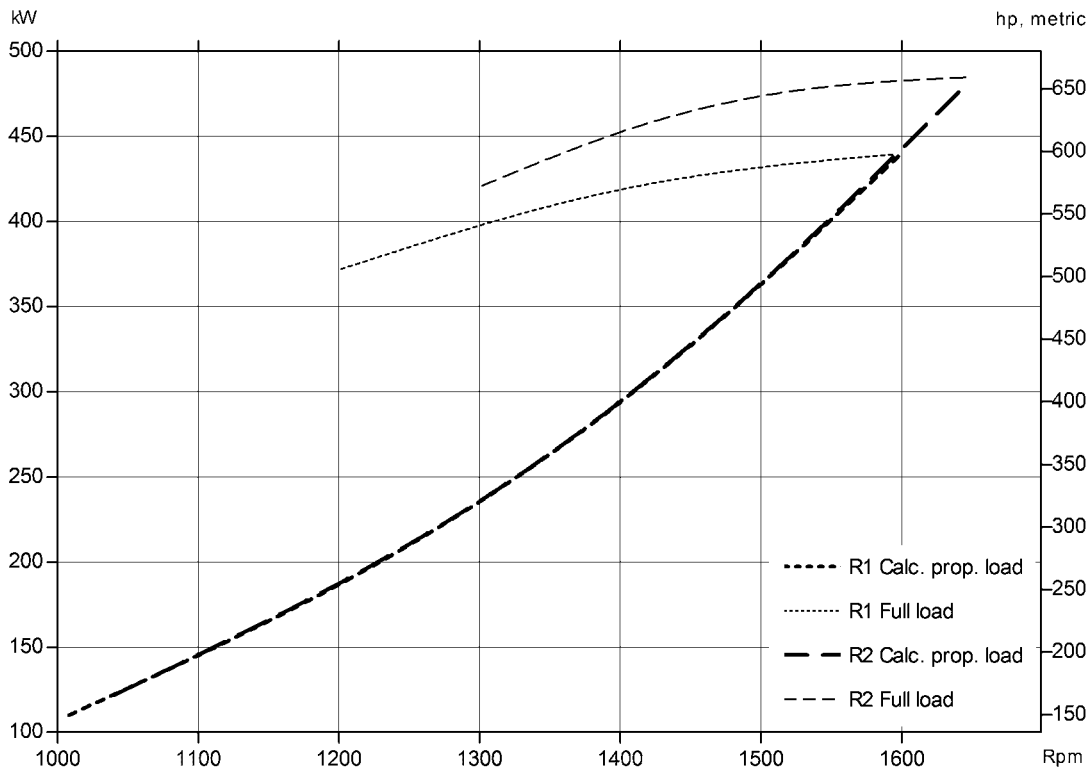

## Torque D25A MS

Torque measured at crankshaft

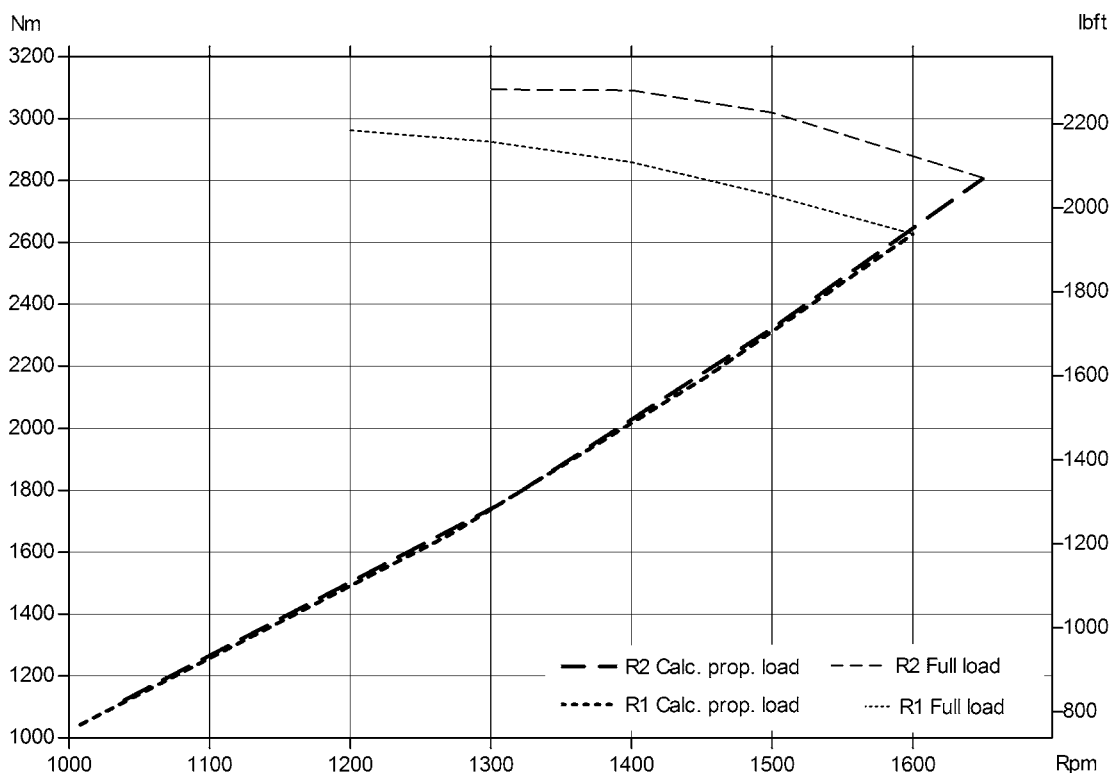

## Specific fuel consumption D25A MS

Based on calculated propeller load

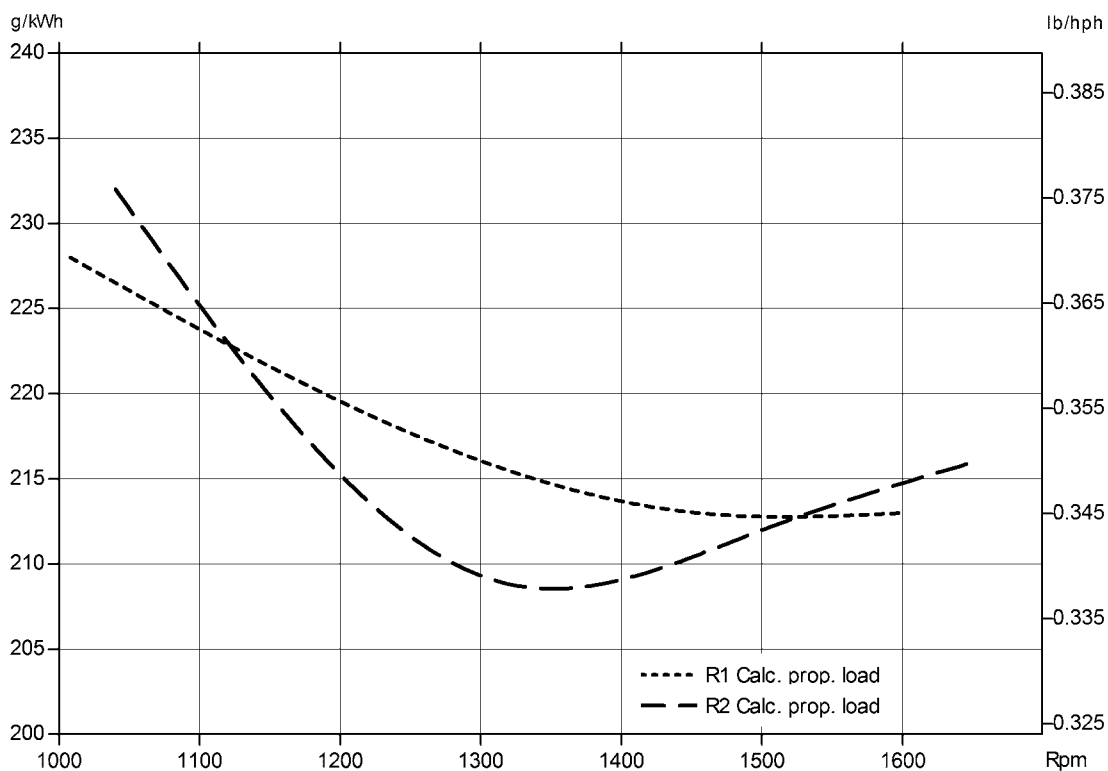

# D25A MS

## Dimensions D25A MS, Heat exchanger cooled

Dimensions in mm. Not for installation

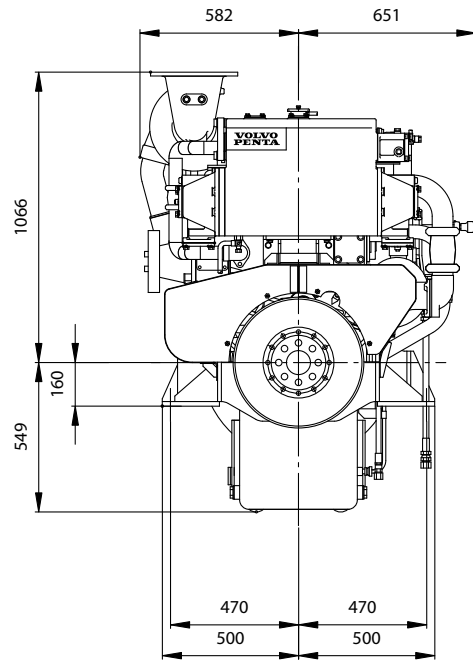
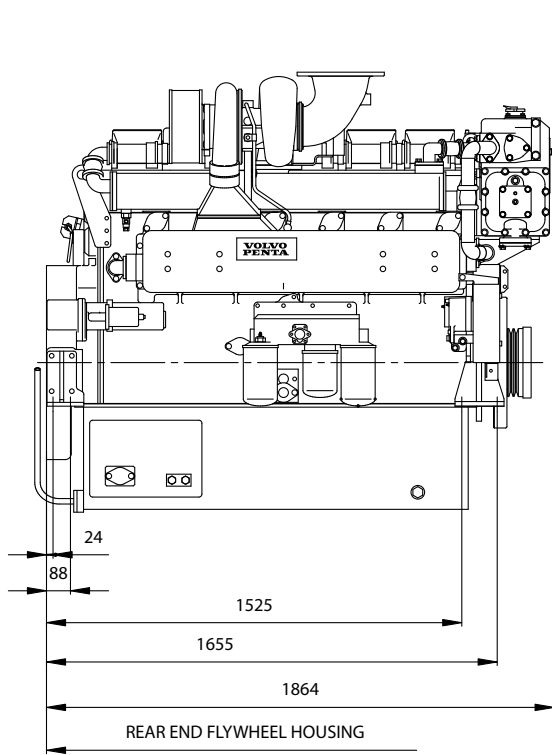

## Dimensions D25A MS, Keel cooled

Dimensions in mm. Not for installation

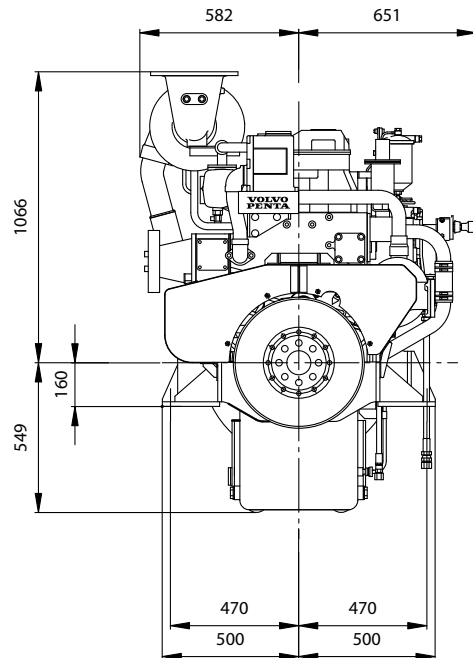
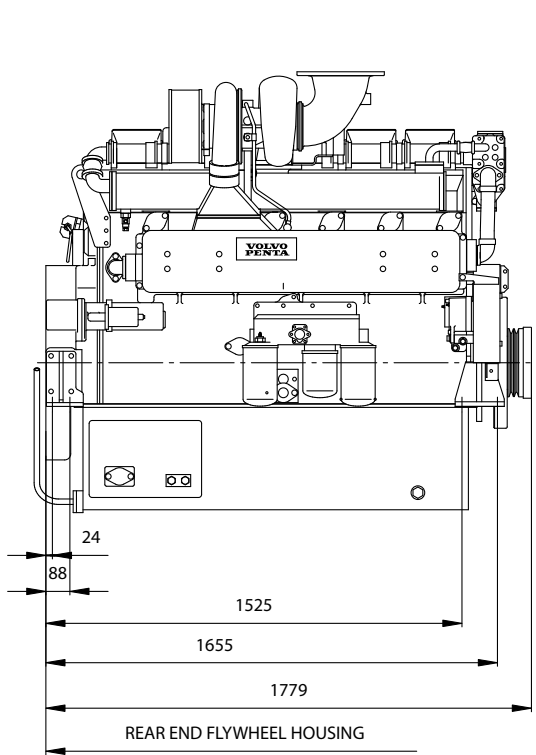

**VOLVO  
PENTA**

**AB Volvo Penta**  
SE-405 08 Göteborg, Sweden  
[www.volvopenta.com](http://www.volvopenta.com)