

D3-110,150



Technical Data

Engine designation	D3-110 I	D3-150 I
Crankshaft power, kW (hp)	81 (110)	110 (150)
Propeller shaft power, kW (hp)	78 (107)	106 (144)
Engine speed, rpm	3000	3000
Displacement, l (in ³)	2.4 (146)	2.4 (146)
Number of cylinders	5	5
Bore/stroke, mm (in.)	81/93.2 (3.19/3.67)	81/93.2 (3.19/3.67)
Compression ratio	16.5:1	16.5:1
Dry weight D3-110/HS25AE, kg (lb)	297 (655)	297 (655)
Dry weight D3-150/HS45AE, kg (lb)	301 (664)	301 (664)
Rating	R5*	R5*
Emission compliance	EU RCD, US EPA Tier 3	

Technical data according to ISO 8665. With fuel having an LHV of 42700 kJ/kg and density of 840 g/liter at 15°C (60°F).

Merchant fuel may differ from this specification which will influence engine power output and fuel consumption.

*RATING 5. For pleasure craft applications, and can be used for high speed planing crafts in commercial applications

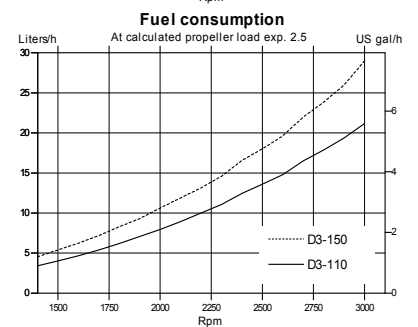
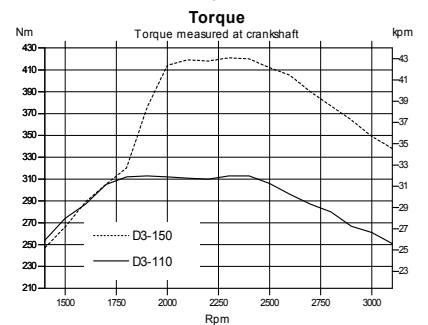
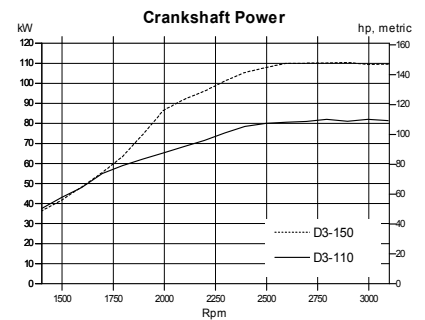

D3-110,150

Technical description:

Engine block and head

- Cylinder block and head made of aluminum
- Cylinder block with integrated bed plate
- 4-valve technology with hydraulic lash adjusters
- Double overhead camshafts
- Oil-cooled pistons with two compression rings and one oil scraper ring
- Cast-in grey iron cylinder liners
- Replaceable valve seats
- Six-bearing crankshaft
- Front-end transmission

Engine mounting

- Flexible engine mounting

Lubrication system

- Easily replaceable (insert) full-flow oil filter
- Plate oil cooler

Fuel system

- Common rail fuel injection system
- Piezo-electric injectors
- Constant power output regardless of fuel quality or temperature (5–55°C / 41–131°F)

- Fine filter with water separator and water in fuel sensor with alarm

Air inlet and exhaust system

- Replaceable air filter
- Closed crankcase ventilation with oil separator and filter
- Stainless steel exhaust elbow
- Turbocharger with variable geometry

Cooling system

- Thermostatically regulated freshwater cooling
- Tubular heat exchanger with separate large volume expansion tank
- Coolant system prepared for hot water outlet
- Easily accessible impeller pump

Electrical system

- 12V one-pole electrical system
- 180A alternator, and integrated temperature compensated charging regulator
- Auxiliary stop button

Instruments/control

- Electronic shift and throttle

- Full range of instrumentation available

Reverse gear

HS25AE Hydraulic – drop center with 8° down angled output shaft.

- Ratio 2.48:1 or 1.92:1 (RH/LH)

HS45AE Hydraulic – drop center with 8° down angled output shaft.

- Ratio 2.43:1 or 2.03:1 (RH/LH)

HS63IVE Hydraulic V-drive.

- Ratio 2.48:1 or 1.99:1 (RH/LH).

Option

U.S.C.G./MED (SOLAS) kit available.

Dimensions D3-110/HS25AE and D3-150/HS45AE

Not for installation

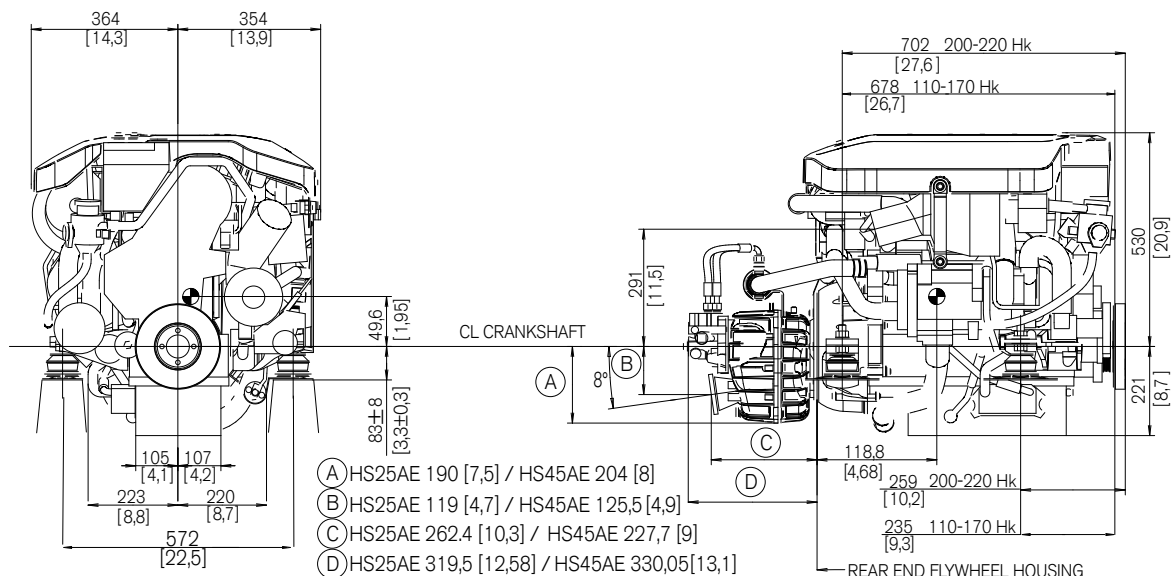

More information

Contact your nearest Volvo Penta dealer for more information about Volvo Penta engines and optional equipment/accessories or go to www.volvopenta.com



IOS



Android

Download the Volvo Penta dealer locator App for your iPhone or Android

VOLVO PENTA

AB Volvo Penta

SE-405 08 Göteborg, Sweden
www.volvopenta.com

Not all models, standard equipment and accessories are available in all countries. All specifications are subject to change without notice. The engine illustrated may not be entirely identical to production standard engines.