

A1	FUEL CONNECTION INLET, 10mm I.D. HOSE
A2	FUEL CONNECTION OUTLET, 10mm I.D. HOSE
A3	FUEL FILTER/WATER SEPARATOR
B1	OIL FILLER ENGINE
B2	OIL FILTER, MAIN
B3	OIL FILTER, BYPASS
B4	OIL DIPSTICK ENGINE PORT STANDARD, CAN BE MOVED TO STARBOARD
B5	OUTLET FOR OIL BILGE PUMP, 12mm/1/2" I.D. HOSE
B6	CRANK CASE VENTILATION FILTER
C1	FRESH WATER FILLER
C2	FRESH WATER DRAIN POINT
C3	CONNECTION HOT WATER INLET R 1/2" (OPTION)
C4	CONNECTION HOT WATER OUTLET R 1/2" (OPTION)
D1	SEA WATER INLET FOR n 38 / 1.5" I.D. HOSE.
D2	SEA WATER DRAIN POINT (2x)
D3	SEA WATER PUMP
D4	WET EXHAUST CONNECTION, 102 mm / 4" I.D. HOSE
D5	EXHAUST RISER (OPTION)
E1	ECU CONTROL UNIT
E2	ENGINE STOP
E3	DIAGNOSE CONNECTOR
E4	DATALINK, SENDER AND AUX (2x)
F1	AIR FILTER
G1	ELASTIC SUSPENSION (4x)
G2	LIFTING EYE, FRONT, n 40
G3	LIFTING EYE, REAR, n 30
H1	OIL DIP STICK TRANSMISSION
H2	OIL DRAIN TRANSMISSION
J1	POWER STEERING PUMP ALT. EXTRA ALTERNATOR (OPTION)
K1	CENTRE OF GRAVITY

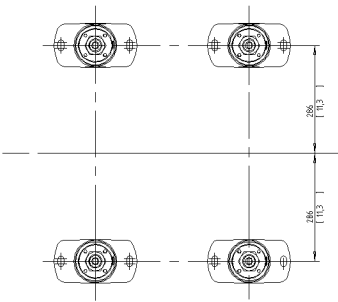
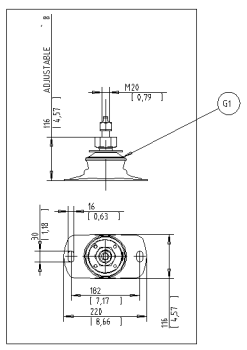
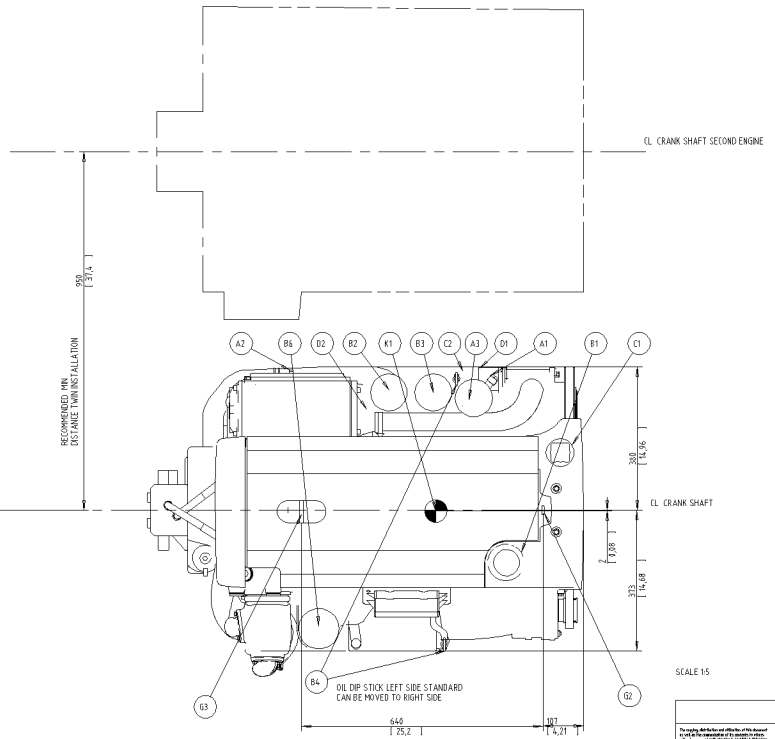

ENGINE DIMENSIONS
 P/N: 2743
 DIMENSION DRAWING
 Scale: 1:5

VOLVO PENTA

21912443