

# VOLVO PENTA INBOARD DIESEL KAMD300

6-cylinder, 24-valve, direct-injected marine diesel engine with charge air compressor, turbocharger, aftercooler and reverse gear. 210 kW (285 hp)\*

\* Crankshaft power according to ISO

## Compressor-charged Hi-Tech propulsion package

Volvo Penta's 6-cylinder KAMD300 is packed with virtually everything. Compressor, turbo and aftercooler, which are precisely controlled by the EDC system (Electronic Diesel Control), all help to produce unmatched diesel performance.

The compressor – fitted with silencers – is controlled by the EDC unit and acts as a “torque controller”. It supplies compressed air at low engine speed and while accelerating, when the extra torque is needed.

The interaction of compressor and turbo produces high torque over the whole speed range, and this contributes to cleaner exhaust gases and fuel economy, giving excellent acceleration and driving characteristics.

## Innovative EDC

Equipped with EDC (Electronic Diesel Control) – an electronically controlled processing system, which optimizes engine performance. The system determines the precise quantity of fuel required at any given moment, taking full account of variation in operating temperatures, air pressure and other contributing factors.

A great advantage with the EDC system is its monitoring of fuel temperature, which keeps the engine on a constant output from 5 to 55°C (41–131°F).

The EDC system includes electric shift and throttle control with wiring giving precise and smooth operation, with no noise transmitted along the cables.

If twin engines are fitted, a synchronizing function keeps the engines on the same rpm.

## High output, excellent power/weight ratio

The engine is compact, and has an advantageous weight to power ratio making it excellent for both single- and multi-engine installation in planing craft.



KAMD300 with HS63AE reverse gear

## Low exhaust emission levels

Direct injection, 4-valve technology, EDC and the advanced combustion system all minimize noxious exhaust emissions and enhance overall enjoyment of boating.

The engine is certified according to SAV and IMO.

## A propulsion package fully matched, tested and supported by one company

Volvo Penta's hydraulically shifted reverse gear has been specially developed with a view to increasing the standard of comfort on board in terms of quiet running, greater reliability and enhanced efficiency.

These benefits originate from a hydraulic shifting mechanism and a gear technology that uses bevel gears throughout the gear train.

The combination of 8° down angle, large drop center and small dimensions provides for optimized installations.

At Volvo Penta, focus is on developing the complete drive line ensuring perfectly matched engine/transmission packages for high torque, operational reliability, reduction of engine noise and vibrations.

In order to get full benefit of the EDC system the reverse gear is equipped with electromagnetic valves for electric gear shifting.

## Easy installation and maintenance

Electronic control and instrument wiring are of plug-in type. The EDC system includes a self-diagnostic facility.

The EDC system makes planning and performing multi-installations easy.

Easily accessible service and maintenance points contribute to the ease of service of the engine.

## Comprehensive service network

Volvo Penta has a well-established network of authorized service dealers in more than 100 countries throughout the world. These service centers offer Genuine Volvo Penta Parts as well as skilled personnel to ensure that you enjoy the best possible service.

**VOLVO  
PENTA**

# KAMD300

## Technical description:

### Engine and block

- Cylinder block and cylinder head made of cast iron for good corrosion resistance and long service life
- 4-valve technology
- Oil-cooled pistons with two compression rings and one oil scraper ring
- Replaceable wet cylinder liners
- Replaceable valve seats
- Seven-bearing crankshaft

### Engine mounting

- Elastic suspension consisting of 4 rubber pads with adjustable anchorage plates for dampening of sound and vibration

### Lubrication system

- Pressure lubrication system with easily replaceable full-flow oil filter
- Tubular oil cooler that can be cleaned

### Fuel system

- Rotor-type injection pump with electronic actuator
- EDC unit for processing the input for precise engine governing
- Two-stage injectors
- Fine filter with water separator
- Feed pump with hand primer
- Electrically operated stopping device

### Air inlet and exhaust system

- Inlet system designed to produce optimal air rotation which provides perfect combustion
- Air inlet silencer with replaceable filter
- Crankcase gases vented into the air inlet
- Seawater-cooled exhaust elbow of cast iron with a stainless steel insert
- Exhaust-driven freshwater-cooled turbo-charger
- Belt-driven compressor with silencer of absorption type on both inlet and outlet port

### Cooling system

- Thermostatically regulated freshwater cooling
- Tubular heat exchanger with separate transparent expansion tank
- Coolant system prepared for hot water outlet
- Easily accessible seawater impeller pump

### Electrical system

- 12V two-pole electrical system
- 14V/60A marine alternator with Zener-diodes to protect entire system from peak voltage
- Charging regulator with battery sensor for voltage drop compensation
- Automatic fuses with manual reset
- Starter motor power 3.0 kW
- Extension cable harness with plug-in connection available in various lengths

### Instruments/control

- Complete instrument panel with key switch, instruments and interlocked alarm. Alternatively separate instruments.
- EDC monitoring panels for single or twin installations
- Electronic remote control for throttle and shift
- Plug-in connections for both EDC and electrics

### Reverse gear

- Reverse gear with matched drop center and 8° down angle for compact installation and minimum propeller shaft angle. V-drive available.
- Bevel gears which results in smooth running at all speeds
- Hydraulically operated clutch for smooth shifting
- Electrical shifting performed by electromagnetic valves
- When under sail propeller shaft can rotate 24 hours without engine start
- Seawater-cooled oilcooler
- Trolling valve available

### Accessories

An extensive range of accessories are available. For detailed information, please see Accessory catalogs.

## Technical Data

Engine designation .....	<b>KAMD300</b>
Crankshaft power, kW (hp) .....	210 (285)
Propeller shaft power, kW (hp).....	202 (275)
Engine speed, rpm.....	3800
Displacement, l (in <sup>3</sup> ) .....	3.6 (219)
Number of cylinders .....	6
Bore/stroke, mm (in.).....	92/90 (3.62/3.54)
Compression ratio .....	16.9:1
Dry weight with HS63AE, kg (lb) .....	539 (1188)
Duty rating/Reverse gear:	
<b>HS63AE</b> .....	R5
Ratio RH (standard): .....	2.52:1, 2.04:1, 1.56:1
LH: .....	2.53:1, 2.02:1, 1.58:1
<b>HS63VE</b> .....	R5
Ratio RH (standard): .....	2.48:1, 2.00:1, 1.56:1
LH: .....	2.53:1, 2.03:1, 1.57:1

Technical data according to ISO 8665. Fuel with a lower calorific value of 42,700 kJ/kg and density of 840 g/liter at 15°C (60°F). Merchant fuel may differ from this specification which will influence engine power output and fuel consumption. The engine is certified according to SAV and IMO.

### Dimensions KAMD300/HS63AE

Not for installation

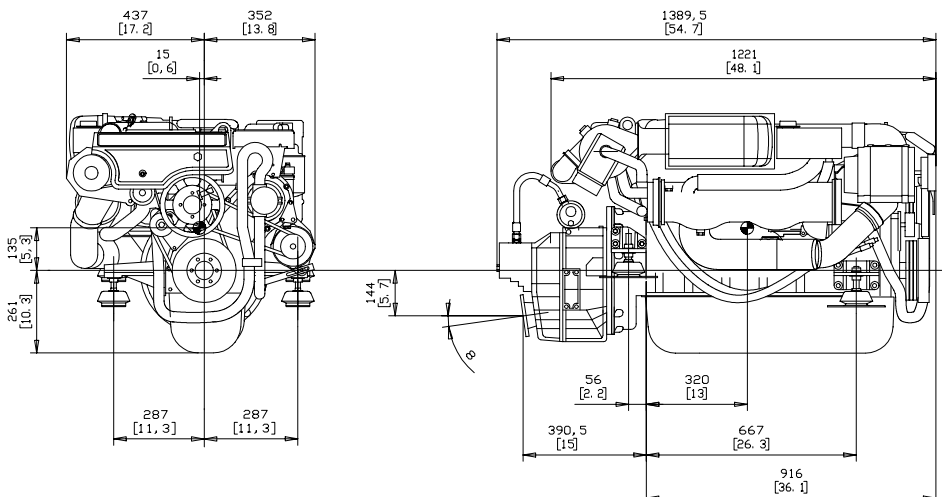

Contact your local Volvo Penta dealer for further information.

Not all models, standard equipment and accessories are available in all countries. All specifications are subject to change without notice.

The engine illustrated may not be entirely identical to production standard engines.

# VOLVO PENTA

**AB Volvo Penta**  
SE-405 08 Göteborg, Sweden  
www.volvopenta.com