

# VOLVO PENTA INDUSTRIAL DIESEL

# TAD1242VE

383 kW (521 hp) crankshaft power acc. to ISO 3046

The TAD1242VE is a powerful, reliable and economical Versatile Diesel Engine built on the dependable Volvo in-line six design.

## Durability & low noise

Designed for the easiest, fastest and most economical installation. Well balanced to produce smooth and vibration-free operation with low noise level, featured with high torque.

To maintain a controlled working temperature in cylinders and combustion chambers, the engine is equipped with piston cooling. The engine is also fitted with replaceable cylinder liners and valve seats / guides to ensure maximum durability and service life of the engine.

## Operational economy and Low exhaust emission

The state of the art, high-tech injection and air charging system with low internal losses contributes to excellent combustion and low fuel consumption.

The TAD1242VE complies with EPA / CARB Tier 2 and EU stage II exhaust emission regulations.

## Easy service & maintenance

Easily accessible service and maintenance points contribute to the ease of service of the engine.

## Technical description:

### Engine and block

- Optimized cast iron cylinder block with optimum distribution of forces without the block being unnecessary heavy.
- Wet, replaceable cylinder liners
- Piston cooling for low thermal load on pistons and reduced ring temperature
- Tapered connecting rods to reduce risk of piston cracking
- Crankshaft induction hardened bearing surfaces and fillets with seven main bearings for moderate load on main and big-end bearings
- Case hardened and nitrocarburized transmission gears for heavy duty operation
- Keystone top compression rings for long service life
- Viscous type crankshaft vibration damper
- Replaceable valve guides and valve seats
- Over head camshaft and four valves per cylinder



### Features

- High torque
- Air to air intercooler
- Fully electronic with Volvo Penta EDC III
- High power density
- EPA / CARB Tier II / EU stage II emission compliant
- Low noise levels

### Lubrication system

- Full flow oil cooler
- Full flow disposable spin-on oil filters, for extra high filtration
- The lubricating oil level can be measured during operation (Standard dipstick only)
- Gear type lubricating oil pump, gear driven by the transmission

### Fuel system

- Non-return fuel valve
- Electronic Unit Injectors
- Fuel prefilter with water separator and water-in-fuel indicator / alarm
- Gear driven low-pressure fuel pump
- Fine fuel filter with manual feed pump and fuel pressure switch

### Turbo charger

- Efficient and reliable turbo charger
- Extra oil filter for the turbo charger

### Cooling system

- Air to air intercooler
- Gear driven, maintenance-free coolant pump with high degree of efficiency

- Efficient cooling with accurate coolant control through a water distribution duct in the cylinder block. Reliable sleeve thermostat with minimum pressure drop
- Tropical radiator
- Radiator guard
- Fan hub
- Suction type fan, 890 mm
- Fan & belt guard

### Electrical system

- Electronic Diesel Control III (EDC III), an electronically controlled processing system which optimizes engine performance. It also includes advanced facilities for diagnostics and fault tracing
- Three different ways for the customer to connect his controls and instrument to the engine. CAN SAE J1939 interface, CIU (Control Interface Unit) and Stand alone connections.
- Sensors for oil pressure, oil temp, boost pressure, boost temp, coolant temp, fuel temp, water in fuel, fuel pressure and two speed sensors.
- Alternator 24V / 60A

**VOLVO  
PENTA**

# TAD1242VE

## Optional equipment

### Engine

- Intermittent and Continuous power settings Tier 2 and Stage II compliance
- Flywheel for Clark and ZF transmissions

### Lubrication system

- Low profile oil sump
- Oil dipstick, flexible type
- Remote oil filter

### Fuel system

- Fuel prefilter
- Fuel system, 2 filters 5my
- Switchable fuel filter kit
- Fuel tank filter

### Intake and exhaust system

- Air filter w/o rain cover
- Silencer, 15 dBA, 5"
- Silencer, 30 dBA, 6"
- Heat guard exhaust manifold

### Control system

- Foot throttle incl. potentiometer

### Electrical system

- Alternator, 28V / 55-80 A
- Starter motor, 24V / 6 kW
- Connection for extra starter motor
- CIU, Control interface unit extension cables
- Instrument panel

### Miscellaneous

- Hydraulic Pump
- Coolant preheater 750 W or 2000 W
- Crankshaft pulley
- Friction clutch
- Air compressors

## Technical Data

Engine designation.....	TAD1242VE
ICFN Net Power at 1800 rpm, kW (hp).....	383 (521)
Torque at 1100-1500 rpm, Nm (lbf ft).....	2250 (1660)
Displacement, l (in <sup>3</sup> ).....	12.13 (740)
Number of cylinders.....	6
Bore/stroke, mm (in.).....	131/150 (5.16/5.91)
Compression ratio.....	17.5:1
Dry weight, kg (lb), Engine / Power pac.....	1240 (2734) / 1645 (3627)

The engine performance corresponds to ISO 3046, BS 5514 and DIN 6271. The technical data applies to an engine without cooling fan and operating on a fuel with calorific value of 42.7 MJ/kg (18360 BTU/lb) and a density of 0.84 kg/litre (7.01 lb/US gal, 8.42 lb/Imp gal), also where this involves a deviation from the standards.

## Dimensions TAD1242VE

Not for installation

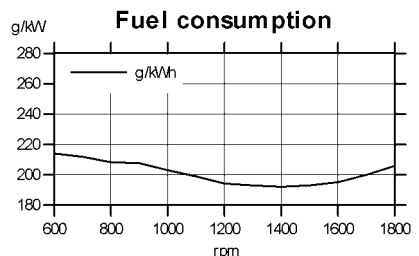
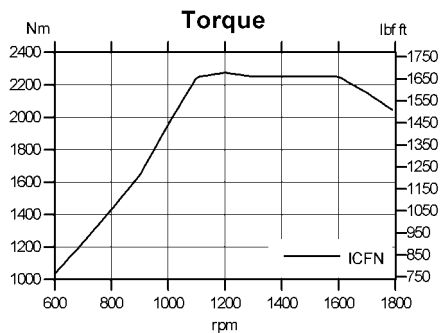
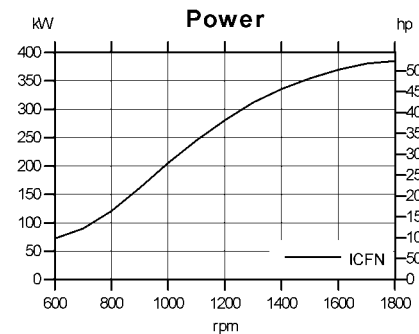
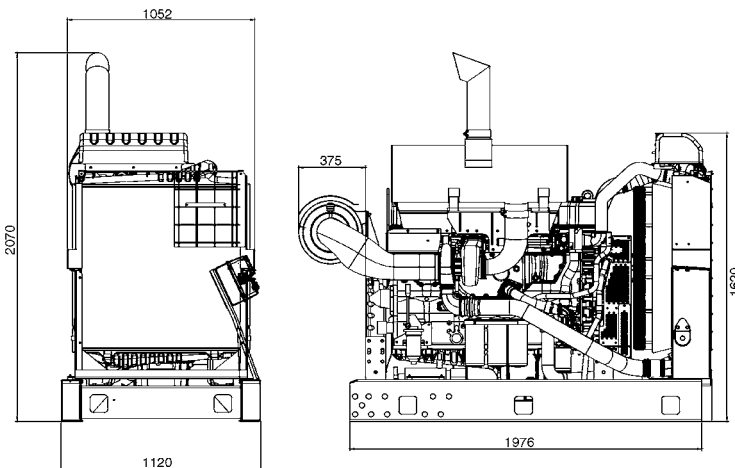

Note! Not all models, standard equipment and accessories are available in all countries. All specifications are subject to change without notice. The engine illustrated may not be entirely identical to production standard engines.

### Power Standards

The engine performance corresponds to ISO 3046, BS 5514 and DIN 6271. The technical data applies to an engine without cooling fan and operating on a fuel with calorific value of 42.7 MJ/kg (18360 BTU/lb) and a density of 0.84 kg/litre (7.01 lb/US gal, 8.42 lb/Imp gal), also where this involves a deviation from the standards.

### Rating Guideline

IFN Power rating corresponds to ISO Overload Power. It is intended for applications where intermittent power is utilized less than 1 hour within any period of 12 hours of continuous operation. The average load factor must not exceed the continuous rating.

ICFN Power rating corresponds to ISO Standard Power for continuous operation. It is intended for constant load applications with uninterrupted service at full load for extended periods of time.

### Derating

The engine will operate up to 1100m altitude without derating. For operation at higher altitudes the power will be derated according to the following factors: Linear interpolation is active between 1100m and 5000 m

Altitude derating factor at 1100 m	0 %/m
Altitude derating factor at 5000 m	10 %/m
Ambient temperature derating factor	No derating
Humidity	No derating

# VOLVO PENTA

**AB Volvo Penta**  
SE-405 08 Göteborg, Sweden  
www.volvopenta.com