

# VOLVO PENTA INDUSTRIAL DIESEL

# TAD1251VE

289 kW (393 hp) crankshaft power acc. to ISO 3046

The TAD1251VE is a powerful, reliable and economical Versatile Diesel Engine built on the dependable Volvo in-line six design.

## Durability & low noise

Designed for the easiest, fastest and most economical installation. Well balanced to produce smooth and vibration-free operation with low noise level, featured with high torque.

To maintain a controlled working temperature in cylinders and combustion chambers, the engine is equipped with piston cooling. The engine is also fitted with replaceable cylinder liners and valve seats/guides to ensure maximum durability and service life of the engine.

## Operational economy and Low exhaust emission

The state of the art, high-tech injection and air charging system with low internal losses contributes to excellent combustion and low fuel consumption.

The TAD1251VE complies with EPA/CARB Tier 3 and EU stage III exhaust emission regulations. These regulations are met by using V-ACT™ (Volvo Advanced Combustion technology).

V-ACT includes a flexible high pressure fuel injection system, an air management system including an internal exhaust gas recirculation device and an enhanced electronic controller.

## Easy service & maintenance

Easily accessible service and maintenance points contribute to the ease of service of the engine.

## Technical description:

### Engine and block

- Optimized cast iron cylinder block with optimum distribution of forces without the block being unnecessarily heavy.
- Wet, replaceable cylinder liners
- Piston cooling for low thermal load on pistons and reduced ring temperature
- Tapered connecting rods to reduce risk of piston cracking
- Crankshaft induction hardened bearing surfaces and fillets with seven main bearings for moderate load on main and big-end bearings
- Case hardened and nitrocarburized transmission gears for heavy duty operation
- Keystone top compression rings for long service life



## Features

- High torque
- Air to air intercooler
- Fully electronic with Volvo Penta EMS 2
- High power density
- EPA CARB Tier 3 / EU stage III emission compliant
- Low noise levels

- Viscous type crankshaft vibration damper
- Replaceable valve guides and valve seats
- Over head camshaft and four valves per cylinder

### Lubrication system

- Full flow oil cooler
- Full flow disposable spin-on oil filters, for extra high filtration
- The lubricating oil level can be measured during operation (Standard dip stick only)
- Gear type lubricating oil pump, gear driven by the transmission
- Oil level sensor at startup

### Fuel system

- Non-return fuel valve
- Electronic Unit Injectors
- Fuel prefilter with water separator and water-in-fuel indicator / alarm
- Gear driven low-pressure fuel pump
- Fine fuel filter with manual feed pump and fuel pressure switch

### Turbo charger

- Efficient and reliable turbo charger
- Extra oilfilter for the turbo charger

### Cooling system

- Air to air intercooler
- Gear driven, maintenance-free coolant

- pump with high degree of efficiency
- Efficient cooling with accurate coolant control through a water distribution duct in the cylinder block. Reliable sleeve thermostat with minimum pressure drop
- Tropical radiator
- Radiator guard
- Fan hub
- Suction type fan, 890mm
- Fan & belt guard

### Electrical system

- Engine Management System 2 (EMS 2), an electronically controlled processing system which optimizes engine performance. It also includes advanced facilities for diagnostics and fault tracing
- The instruments and controls connects to the engine via the CAN SAE J1939 interface, either through the Control Interface Unit (CIU) or the Digital Control Unit (DCU).
- Sensors for oil pressure, oil temp, boost pressure, boost temp, coolant temp, fuel temp, water in fuel, fuel pressure and two speed sensors. Crankcase pressure, piston cooling pressure, oil level and air filter pressure drop sensors
- Alternator 80A / 28V

**VOLVO  
PENTA**

# TAD1251VE

## Technical Data

### General

Engine designation .....	TAD1251VE
No. of cylinders and configuration .....	in-line 6
Method of operation .....	4-stroke
Bore, mm (in.) .....	131 (5.16)
Stroke, mm (in.) .....	150 (5.91)
Displacement, l (in <sup>3</sup> ) .....	12.13 (740)
Compression ratio .....	18.1:1
Dry weight, kg (lb) .....	1220 (2690)
Wet weight, kg (lb) .....	1270 (2800)

### Performance

ICFN Power, without fan, at 1800 rpm, kW (hp) .....	289 (393)
ICFN Power, with fan Ø890mm, at 1800 rpm, kW (hp) .....	269 (366)
Torque at 1200 rpm. Nm (lbf ft) .....	1950 (1438)
Mean piston speed at 1900 rpm, m/s (ft/s) .....	9.5 (31.2)
Effective mean pressure at 1900 rpm, MPa (psi) .....	1.42 (14.2)
Friction power at 1900 rpm, kW (hp) .....	45 (61)

### Lubrication system

Oil consumption at max rpm, l/h (US gal/h) .....	0.07 (0.018)
Oil system capacity incl filters, liter (US gal) .....	35 (9.25)

For details see Technical data

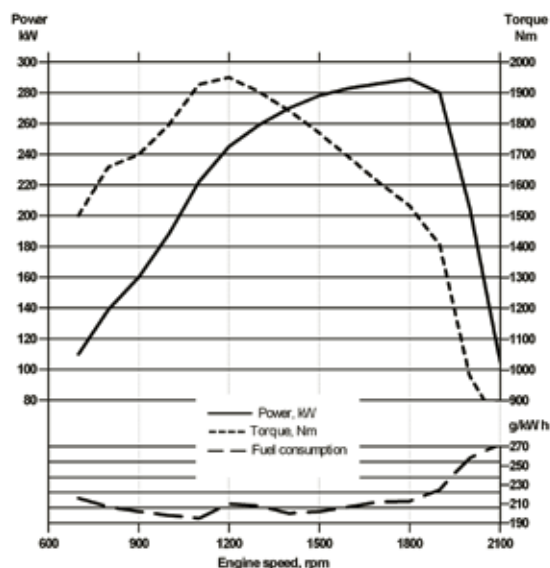

## Dimensions TAD1251VE

Not for installation

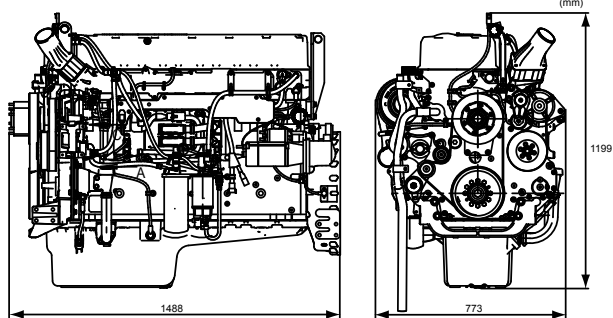

Note! Not all models, standard equipment and accessories are available in all countries. All specifications are subject to change without notice. The engine illustrated may not be entirely identical to production standard engines.

### Power Standards

The engine performance corresponds to ISO 3046, BS 5514 and DIN 6271. The technical data applies to an engine without cooling fan and operating on a fuel with calorific value of 42.7 MJ/kg (18360 BTU/lb) and a density of 0.84 kg/litre (7.01 lb/US gal, 8.42 lb/Imp gal), also where this involves a deviation from the standards.

### Rating Guideline

IFN Power rating corresponds to ISO Overload Power. It is intended for applications where intermittent power is utilized less than 1 hour within any period of 12 hours of continuous operation. The average load factor must not exceed the continuous rating.

ICFN Power rating corresponds to ISO Standard Power for continuous operation. It is intended for constant load applications with uninterrupted service at full load for extended periods of time. The average load factor must not exceed 70% of the continuous rating when operating at continuous speed and load.

### Derating

The engine will operate up to 2000m altitude without derating. For operation at higher altitudes, see technical data.

## Standard and optional equipment

### Engine

- Automatic belt tensioner •
- Lift eyelets •
- Flywheel housing with conn. acc. to SAE 1 •
- Flywheel for 14" flex. plate and flexible coupling •
- Flywheel for ZF and DANA –
- Vibration dampers •

### Engine suspension

- Fixed front and rear suspension •

### Lubrication system

- Oil dipstick •
- Oil dipstick, flexible –
- Full-flow oil filter of spin-on type –
- By-pass oil filter of spin-on type •
- Remote oil filter of spin-on type –
- Oil cooler, side mounted •
- Low noise oil sump •

### Fuel system

- Fuel filters of disposable type •
- Electronic unit injectors •
- Pre-filter with water separator and water-in-fuel indicator/alarm •

### Intake and exhaust system

- Air filter without rain cover –
- Air filter with replaceable paper insert –
- Connecting flange for exhaust pipe •
- Exhaust flange with v-clamp •
- Turbo charger, low right side •
- Crankcase ventilation, open •

### Cooling system

- Tropical radiator incl. intercooler –
- Gear driven coolant pump •
- Fan hub •
- Suction fan, 750 mm, with fan ring –
- Suction fan, 890 mm –
- Thrust fan, 890 mm –
- Fan guard –
- Belt guard –

### Control system

- Engine Management System 2 (EMS 2) with CAN-bus interface SAE J1939 •
- CIU, Control Interface Unit –
- DCU, Display Control Unit –

### Alternator

- Alternator 80A / 28V •
- Alternator 110A / 28V •
- Alternator 140A / 28V •

### Starting system

- Starter motor, 6kW, 24V •
- Connection facility for extra starter motor •
- Air pre-heater –

### Instruments and senders

- Temp. and oil pressure for automatic stop/alarm •

### Other equipment

- Air compressor, 1 cylinder –
- Air compressor, 2 cylinders –
- AC compressor –

### Engine Packing

- Plastic wrapping •

- optional equipment or not applicable,
- included in standard specification

# VOLVO PENTA

AB Volvo Penta

SE-405 08 Göteborg, Sweden  
www.volvopenta.com