

TAD1350VE

NEW!

The TAD1350VE is a powerful, reliable and economical Versatile Diesel Engine built on the dependable Volvo in-line six concept.

Durability & low noise

Designed for easy, fast and economical installation. Field tested to ensure highest standard of durability and long life. Well-balanced to produce smooth and vibration-free operation with low noise levels and high torque.

To maintain a controlled working temperature in cylinders and combustion chambers, the engine is equipped with piston cooling. The engine is also fitted with replaceable cylinder liners and valve seats/guides to ensure maximum durability and service life of the engine.

Low exhaust & noise emission

The state of the art, high-tech injection and highly efficient charge air system with low internal losses contributes to excellent combustion and low fuel consumption.

The TAD1350 VE complies with EU Stage IIIA emissions. An electronically controlled viscous fan drive is available giving substantially lower noise and fuel consumption.

Easy service & maintenance

Easily accessible service and maintenance points contribute to the ease of service of the engine.

Technical description

Engine and block

- Cast iron cylinder block with optimum distribution of forces without the block being unnecessarily heavy.
- Wet, replaceable cylinder liners
- Piston cooling for low piston temperature and reduced ring temperature
- Tapered connecting rods for increased piston lifetime
- Crankshaft with induction hardened bearing surfaces and fillets with seven bearings for moderate load on main and big-end bearings
- Case hardened and Nitrocarburized transmission gears for heavy duty operation
- Keystone top compression rings for long service life
- Viscous type crankshaft vibration dampers
- Replaceable valve guides and valve seats
- Overhead camshaft and four valves per cylinder



Features

- High torque
- Highly efficient cooling system with Air to Air Intercooler
- Fully electronic with EMS 2
- Complies with EU Stage IIIA emissions
- Wide range of optional equipment including visco fan.

Lubrication system

- Full flow oil cooler
- Full flow disposable spin-on oil filter
- The lubricating oil level can be measured during operation
- Gear type lubricating oil pump, gear driven by the transmission
- Oil level sensor at startup

Fuel system

- Electronic high pressure unit injectors
- Fuel prefilter with water separator and water-in-fuel indicator / alarm
- Gear driven low-pressure fuel pump
- Fine fuel filter with manual feed pump and fuel pressure switch

Cooling system

- Efficient cooling with accurate coolant control through a water distribution duct in the cylinder block. Reliable sleeve thermostat with minimum pressure drop
- Belt driven coolant pump with high degree of efficiency
- Electronically controlled viscous fan drive provides lower noise and fuel consumption (optional).

Turbocharger

- Efficient and reliable turbocharger
- Electronically controlled Wastegate

Electrical system

- Engine Management System 2 (EMS 2), an electronically controlled processing system which optimizes engine performance. It also includes advanced facilities for diagnostics and fault tracing.
- Possibility to perform a start battery test according to the NCPA requirements via CAN bus signals.
- The instruments and controls connect to the engine via the CAN SAE J1939 interface, either through the Control Interface Unit (CIU) or the Digital Control Unit (DCU). The CIU converts the digital CAN bus signal to an analog signal, making it possible to connect a variety of instruments. The DCU is a control panel with display, engine control, monitoring, alarm, parameter setting and diagnostic functions. The DCU also presents error codes.
- Sensors for oil pressure, oil temp, boost pressure, boost temp, coolant temp, water in fuel, fuel pressure and two speed sensors.

**VOLVO
PENTA**

TAD1350VE

Technical Data

General

Engine designation TAD1350VE
 No. of cylinders and configuration in-line 6
 Method of operation 4-stroke
 Bore, mm (in.) 131 (5.16)
 Stroke, mm (in.) 158 (6.22)
 Displacement, l (in³) 12.78 (780)
 Compression ratio 18.1:1
 Wet weight, engine only, kg (lb) 1325 (2921)

Engine	kW	Hp	rpm	Max Nm
TAD1350VE	256	348	1900	1780

For details see Technical Data

Dimensions TAD1350VE

Not for installation

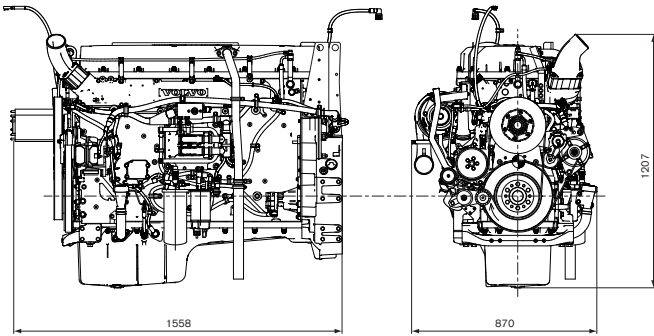

Power Standards

The engine performance corresponds to ISO 3046, BS 5514 and DIN 6271. The technical data applies to an engine without cooling fan and operating on a fuel with calorific value of 42.7 MJ/kg (18360 BTU/lb) and a density of 0.84 kg/litre (7.01 lb/US gal, 8.42 lb/Imp gal), also where this involves a deviation from the standards.

Derating

For derating information please see technical diagrams available on request from Volvo Penta.

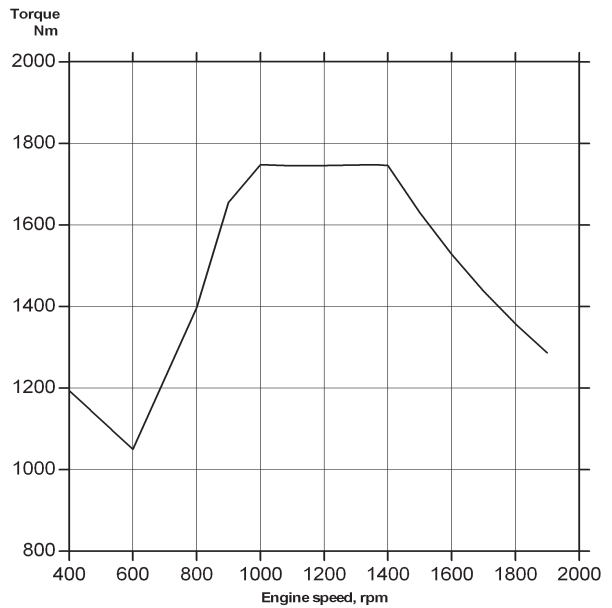
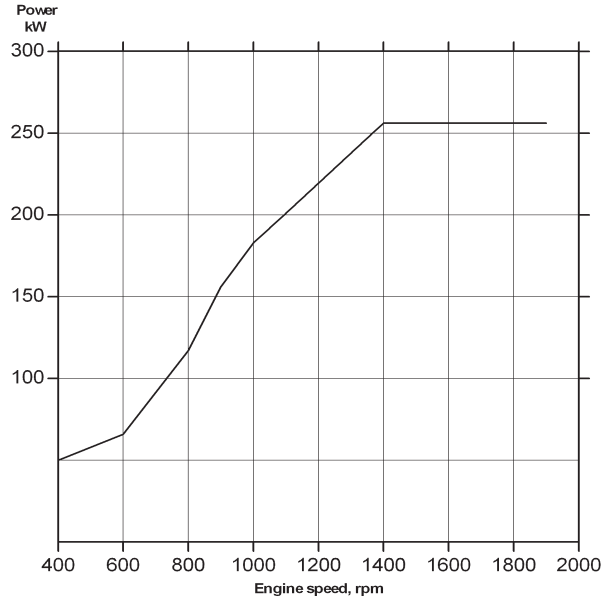

VOLVO PENTA

AB Volvo Penta

SE-405 08 Göteborg, Sweden
www.volvopenta.com

Not all models, standard equipment and accessories are available in all countries. All specifications are subject to change without notice. The engine illustrated may not be entirely identical to production standard engines.