

V-CLAMP  
TURBO CHARGER  
11

EXHAUST FLANGE  
11

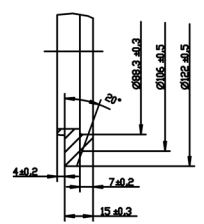

VIEW RR  
AIR COMPRESSOR PTO  
12

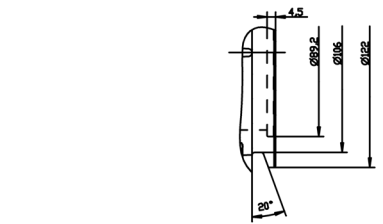
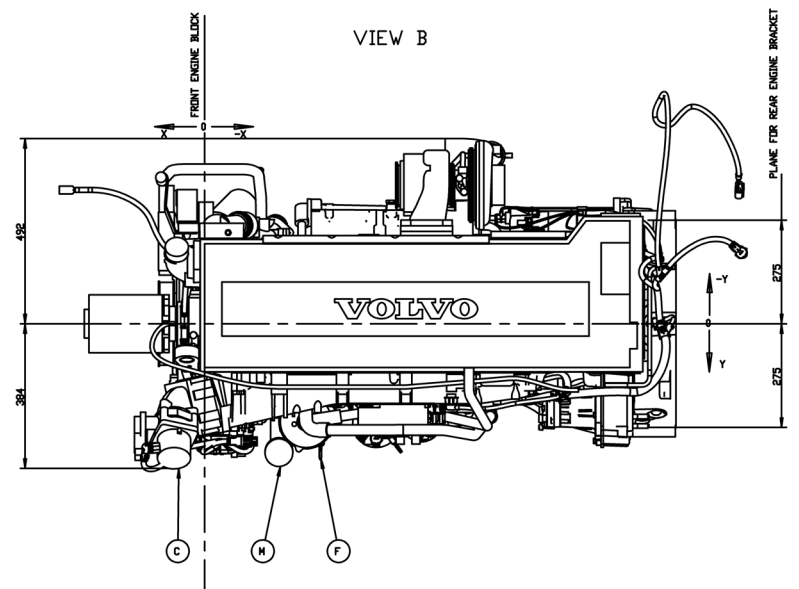
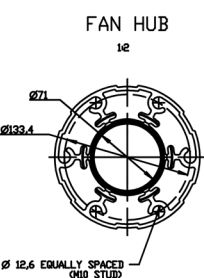
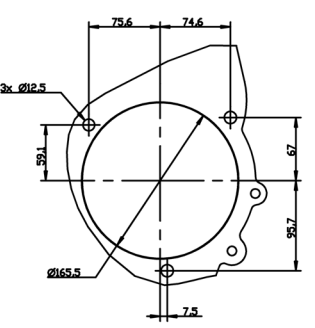

PDS	DESCRIPTION	X	Y	Z	NOTE
A	WATER FROM ENGINE HEATER	-1010	128	495	PIPE CONNECTION TO FIT Ø22
B	WATER TO ENGINE HEATER	-194	-201	235	M18x1.5
C	CHARGE AIR FROM CAC	81	357	730	Ø90
D	HUMIDITY SENSOR				
E	WATER DRAIN COOK	-470	-224	185	M22x1.5
F	OIL DIP STICK	-307	357	-33	
G	FUEL INLET	-402	227	167	Ø9.5
	FUEL INLET OPTIONAL				3/8" NPSF
H	FUEL RETURN	-522	-341	55	Ø6.35
	FUEL RETURN OPTIONAL				1/4" NPSF
I	AIR INTAKE	-796	-368	380	Ø106
J	EXHAUST OUTLET	-507	-369	380	V-CLAMP Ø122
K	WATER INLET	-191	-262	10	Ø60
L	WATER OUTLET	74	-296	363	Ø60
M	OIL FILLER CAP	-198	342	49	
N	OIL PRESSURE SENDER	-725	107	198	EMS
O	WATER TEMP SENDER	-61	-205	423	EMS
P	OPTIONAL SPEED SENDER	-1162	250	117	M18x1.5 GEAR RATIO 11 153 TEETH
Q	FROM EXPANSION TANK	116	-389	511	Ø28
R	CHARGE AIR TO CAC	-613	-446	149	Ø90
S	AIR FILTER INDICATOR				
T	OIL DRAIN PLUG	-180	0	-437	M24x1.5
U	OIL TEMP SENDER	-360	188	-178	EMS
V	CRANK CASE VENTILATION	-756	240	21	Ø38
W	OIL TO AIR COMPRESSION	-781	126	162	M24x1.5
X	CENTRAL UNIT				
Y	FAN HUB	284	0	337	
Z	AIR VENT HOSE Ø 9.5 TO BE CONNECTED TO EXP. TANK	-62	-242	565	Ø10
AA	COOLANT LEVEL SENSOR				FOR VOLVO PENTA EXPANSION TANK
BB	AUX REMOTE STOP, DIAGNOSIS AND ENGINE INTERFACE	-499	294	309	
CC	AUX. STOP	-548	297	404	
DD	UREA HEATER INLET	-147	-390	170	INLET M14
	OUTLET	-234	-191	375	OUTLET M18
EE	CAB HEATER INLET	-145	-410	211	INLET M14
	OUTLET	-274	-191	375	OUTLET M18
FF	WATER TO COMPRESSOR	-940	-149	292	Ø30
GG	WATER FROM COMPRESSOR	-110	-202	220	M22 x 1.5
TP	CENTRE OF GRAVITY	-614	11	210	

SCALE 1:5

<p>ENGINE DIMENSIONS TAD1360-6SVE / ENGINE</p> <p><b>VOLVO PENTA</b></p> <p>21541195</p>	<p>DIMENSION DRAWING</p> <p>102</p>
	<p>1:10</p>