

TAD1371-1375VE

NEW!

TAD1371-1375VE is a powerful, reliable and economical off-road Diesel Engine range built on the Volvo in-line six concept.

Low cost of ownership

World class fuel efficiency combined with a reliable exhaust aftertreatment system gives high uptime as well as low cost of ownership. No downtime for regeneration or decreased service intervals.

Compact & simple installation

SCR technology selected by Volvo does not increase amount of cooling capacity needed. As optional equipment all material needed in order to install the engine can be ordered from Volvo Penta. Installation guidelines as well as drawings and CAD models are easy to access. The result is an engine and aftertreatment system that is easy to install.

Durability & low noise

Long experience with SCR systems in combination with base engine development reduces risk of downtime. Well-balanced to produce smooth operation with low noise.

Power & torque

Maximum power and torque available at low rpm. As a result noise as well as fuel consumption is very low. Useful engine speed for the TAD1371-1375VE is due to power and torque layout very flexible.

Low exhaust emission

Efficient injection as well as robust engine design in combination with optimised SCR technology and a light EGR contributes to excellent combustion and low fuel consumption. TAD1371-1375VE complies with EU Stage IV / EPA Tier 4f emissions.

Easy service & maintenance

Easily accessible service and maintenance points contribute to the ease of service of the engine. As optional equipment possible to remote mount filters and service points.



Features & Benefits

- Low cost of ownership and operation due to SCR technology
- Proven and straight-forward design
- Compact and simple installation
- High power and torque available at low engine speed
- Complies with EU Stage IV / EPA Tier 4f
- Wide range of optional equipment, please see order specification
- No regeneration needed

Technical description

Engine and block

- Cast iron cylinder block
- Wet, replaceable cylinder liners
- Replaceable valve guides and valve seats
- Overhead camshaft and four valves per cylinder

Lubrication system

- Full flow disposable spin-on oil filter, for extra high filtration
- Gear type lubricating oil pump, gear driven by the transmission
- Oil level sensor at startup

Fuel system

- Electronic high pressure unit injectors
- Fuel prefilter with water separator and water-in-fuel indicator / alarm
- Gear driven low-pressure fuel pump
- Fine fuel filter with manual feed pump and fuel pressure switch

Cooling system

- Available as Power pack or base engine.
- Belt driven coolant pump with high degree of efficiency

Turbo charger

- Electronically controlled Waste-gate

Electrical system

- Engine Management System 2 (EMS 2.3), an electronically controlled processing system which optimizes engine performance.
- The instruments and controls connect to the engine via the CAN SAE J1939 interface. Options available for engine control equipment.

Exhaust aftertreatment system

- Emission levels compliance through SCR and light EGR technology
- Several DEF tanks available as options
- Possibility to offer a wide range of installation material needed
- Airless urea injection

**VOLVO
PENTA**

TAD1371-1375VE

Technical Data

General

Engine designation	TAD1371-1375VE
No. of cylinders and configuration.....	in-line 6
Method of operation	4-stroke
Bore, mm (in.).....	131 (5.16)
Stroke, mm (in.).....	158 (6.22)
Displacement, l (in ³).....	12.78 (780)
Wet weight, engine only, kg (lb)	1325 (2921)

Engine	kW	Hp	rpm	Max Nm
TAD1371VE	285	388	1900	1965
TAD1372VE	315	428	1900	2175
TAD1373VE	345	469	1900	2380
TAD1374VE	375	510	1900	2595
TAD1375VE	405	551	1900	2650

For details see Technical Data

Main components, Principal layout

The illustration shows the main components of the aftertreatment system and its piping connections.

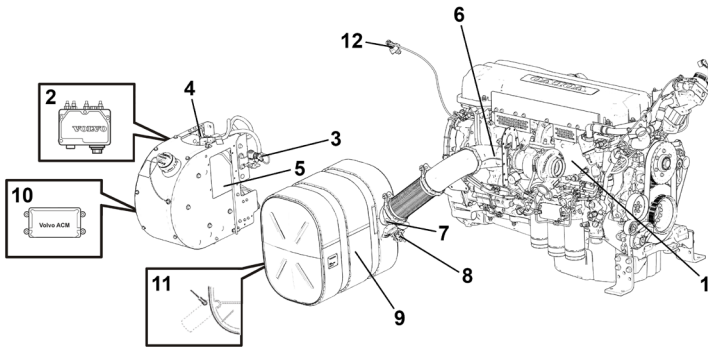

- 1 Engine
- 2 Pump Unit (PU)
- 3 Solenoid Valve, heating/cooling
- 4 AdBlue®/DEF Level Sensor
- 5 AdBlue/DEF Solution Tank
- 6 NOx Sensor
- 7 Temperature Sensor Exhaust
- 8 Dosage Valve (DV)
- 9 Muffler with Catalytic Converter
- 10 Aftertreatment Control Module (ACM)
- 11 NOx Sensor
- 12 Temperature Sensor Air

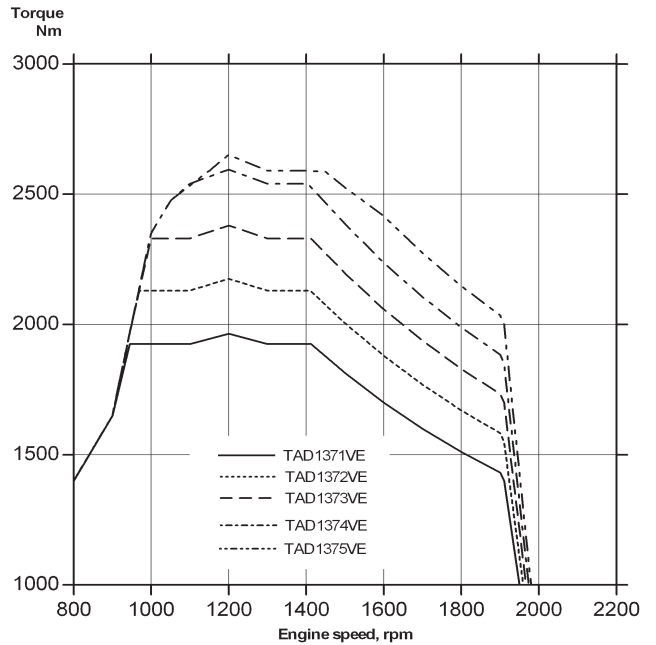
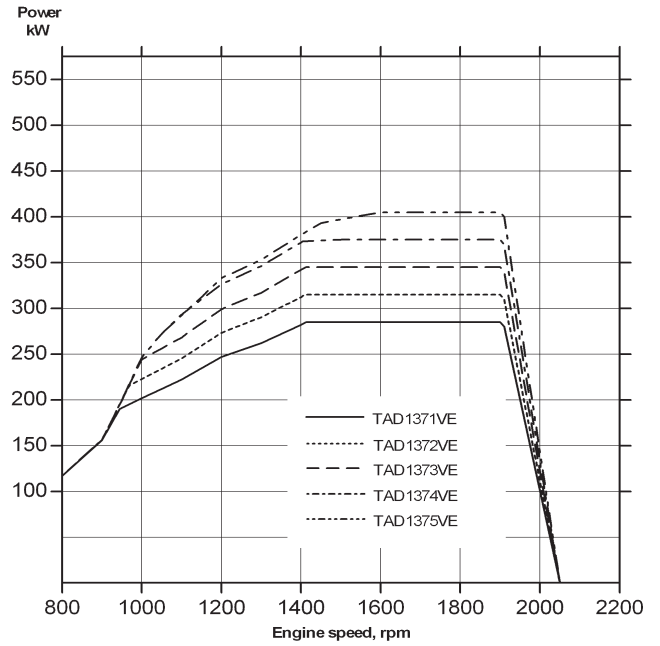

Dimensions TAD1371-1375VE

Not for installation

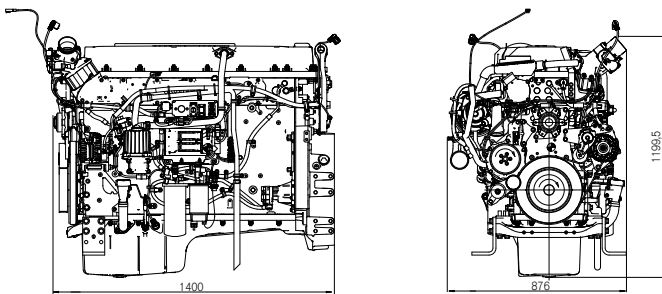

Power Standards

The engine performance corresponds to ISO 3046, BS 5514 and DIN 6271. The technical data applies to an engine without cooling fan and operating on a fuel with calorific value of 42.7 MJ/kg (18360 BTU/lb) and a density of 0.84 kg/litre (7.01 lb/US gal, 8.42 lb/Imp gal), also where this involves a deviation from the standards.

Not all models, standard equipment and accessories are available in all countries. All specifications are subject to change without notice. The engine illustrated may not be entirely identical to production standard engines.

® = Registered trademark of the Verband der Automobilindustrie e.V. (VDA).

VOLVO PENTA

AB Volvo Penta

SE-405 08 Göteborg, Sweden
www.volvopenta.com