

TAMD61A

6-cylinder, 4-stroke, direct-injected, turbocharged marine diesel with aftercooler – crankshaft power* 225 kW (306 hp)

The TAMD 61A is a powerful, reliable and economical marine diesel. Thanks to Volvo Penta's extremely comprehensive range of equipment, this engine can be perfectly matched to specific customer and market demands.

The engine block and cylinder heads are made of cast steel. The cylinder linings incorporate a flame barrier which protects the cylinder head gasket. Each cylinder head is tightened down with 20 screws. The pistons are oil-cooled, which reduces the amount of carbon deposits. The heat exchanger and charge air cooler matrices are identical, which means that they are fully interchangeable.

The electrical system is a 12 V system of the plug-in variety with all electrical wiring included. Alternatively a 24 V electrical system may be specified. Automatic heating of the induction air ensures reliable starting at low temperatures.

The injection pump is equipped with a smoke limiting device which reduces the emission of smoke during swift acceleration and under heavy loads. A bypass valve between the turbocharger and the charge air cooler (after cooler) reduces the emission of white fumes when the engine is started and when it is operated under conditions of low load. An automatic wastegate controls the degree of boost, either through the charge air cooler (after cooler) or at low speeds directly through the induction manifold.

The coolant pump is gear-operated and the raw water pump is mounted on the front of the timing case for ease of service. The oil filter and oil filler are also mounted on the front of the engine.

Volvo Penta has a well-established service network in more than 100 countries. Authorized workshops using genuine parts and staffed by skilled personnel provide the customer with the best possible service.

* Crankshaft power according to ISO 8665.

Technical description of the engine:

- Cylinder block and head of alloyed cast steel
- Replaceable cylinder linings and valve seats
- Nitro-carbonated crankshaft with seven main bearings
- Two cylinder heads
- Forged pistons featuring oil cooling
- Engine suspension
- Expansion tank
- 12 V starter motor
- Electrical engine cut-out control 12 V
- Oil pressure and temperature sensors
- Electrical pre-heater element incl. relays, 12 V
- Electrical junction box with automatic fuses
- Front-mounted oil filter of spin-on type for ease of service
- Freshwater-cooled oil cooler
- Injection pump with centrifugal regulator and smoke limiter
- Feed pump
- Double fine filters
- Freshwater-cooled turbocharger
- Freshwater-cooled exhaust manifold
- UNIQUE bypass valve for charge air cooling. This produces less white fumes when the engine is started and when it is operated under low load conditions

Extra equipment

Engine:

- Flexible mountings for engine and reverse gear
- Oil filling on right-hand side

Cooling system:

- Heat exchanger with seawater pump or keel cooling
- Seawater filter

Fuel system:

- Single fuel filter/water separator
- Double fuel filter/water separator

Controls:

- Stop solenoid and engine speed control panel for control cables

Electrical system:

- 24 V electrical system
- 12 V/50 A or 24 V/60 AC alternator
- For more demanding charging requirements, it is possible to specify an extra 12 V/130 A or 24 V/100 A alternator
- Instrument panels and connecting cables between the engine and the instrument panel

Power transmission:

- Crankshaft pulley
- Hydraulic pump for steering and other purposes
- Reverse gear:
 - MPM IRM 220A, ratio 1.53:1 – 2.04:1
 - Twin Disc MG506, ratio 1.50:1 – 2.50:1
 - Twin Disc MG506A, ratio 1.10:1 – 2.50:1
 - Twin Disc MG5061A, ratio 1.13:1 – 2.47:1
 - Twin Disc MG 5061SC ratio 1.15:1 – 3.00:1
 - Twin Disc MG507-1 ratio 1.10:1 – 2.99:1
 - Twin Disc MG507A-1 ratio 1.51:1 – 2.54:1
 - Twin Disc MG509 ratio 3.83:1 – 4.50:1
- Slip valve for TDMG506 and TDMG506A

Exhaust system:

- Flexible exhaust pipe. Dry silencer
- Exhaust elbow, wet or dry

Miscellaneous:

- Tool kit and replacement parts for the engine and reverse gear

Please contact your Volvo Penta dealer for further information.

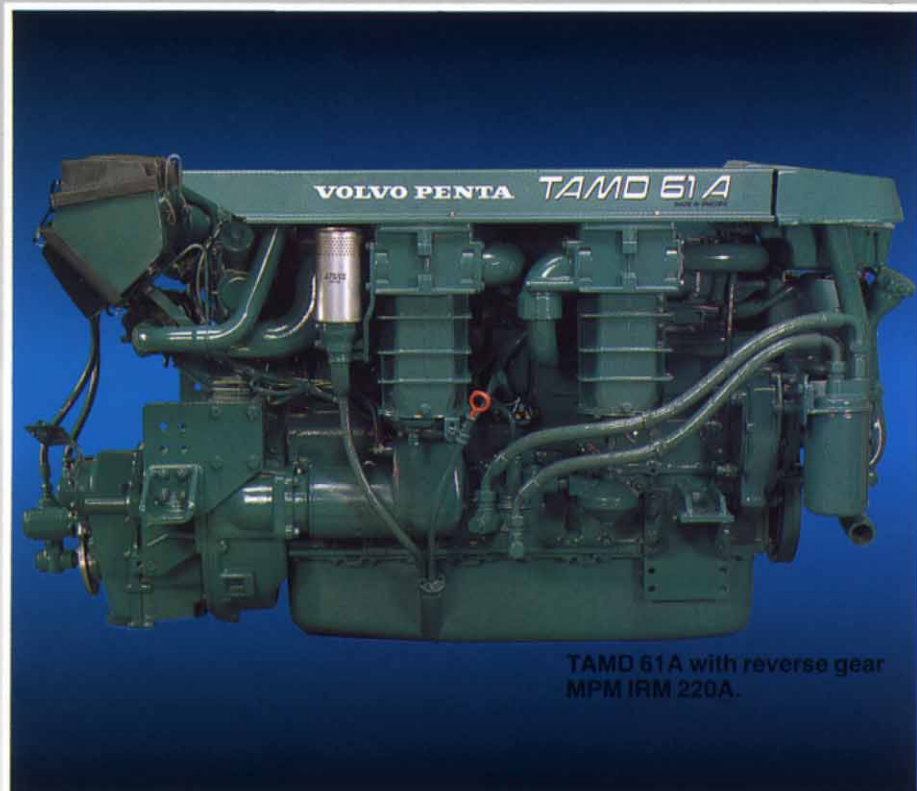

TAMD 61A with reverse gear
MPM IRM 220A.

återförsäljare.

**VOLVO
PENTA**

TAMD61A

Technical data, TAMD 61A marine engine

ENGINE:

Type designation	TAMD 61A
No. of cylinders and configuration	in-line six cylinder unit
Des. principle	4-stroke direct-injected, turbocharged and charge air cooled diesel engine
Fuel quality ASTM	1D or 2D
Cylinder bore, mm (in)	98.42 (3.87)
Stroke, mm (in)	120 (4.7)
Displacement, litres (in ³)	5.46 (333)
Compression ratio	15:1
Weight excluding water and oil, kg (lb)	760 (1676)

	APPLICATION	
	PD/LD	MD
Crankshaft power**, kW (hp)	225 (306)	168 (228)
at crankshaft, rpm	2800	2500
Torque***, Nm (ft. lb)	769 (567)	644 (475)
Specific fuel consumption***, g/kWh (lb/hph)	237 (0.38)	225 (0.36)
REVERSE GEAR		
Type designation	IRM220A	MG507A-1
Ratios	1.53:1 2.04:1	1.51:1 1.98:1
ENGINES WITH REVERSE GEAR****		
Propeller shaft power**, kW (hp)	218 (296)	162 (220)
at crankshaft, rpm	2800	2500
Weight excluding water and oil, kg (lb)	829 (1828)	921 (2030)

Definition of the different applications

Curve PD: Pleasure boats

Engines with this power rating are intended solely for use in pleasure boats. Normal application in a pleasure boat means that the owner uses the boat solely for recreational purposes.

Curve LD: Light Commercial Applications

Engines with this power rating are intended for applications in which loads and engine speed vary and maximum power is used for a maximum of 1 hour per 12-hour operational period. Primarily intended for planing boats.

Examples: fire tenders, rescue boats, certain patrol boat applications and charter boats.

Curve MD: Medium Duty Com. Applications

Engines with this power rating are intended for applications in which load and engine speed vary, and maximum power is utilized for a maximum of 4 hours per 12-hour operational period.

Planing, semi-planing or displacement boats. Examples: Coastal fishing vessels, patrol boats, police and towboats, passenger ferries etc.

**ISO 8665 (= SAE J1228 = ICOMIA 28-83)

***Torque and specific consumption relate to stated crankshaft power output.

****The stated data applies to the first reverse gear specified under the "Reverse Gears" heading and the first ratio in the table. Propeller shaft power and weight may vary with different reverse gears and ratios.

Power, torque and fuel consumption figures refer to a run-in engine and ISO standard atmospheric conditions, 25°, 100 kPa and 30% relative humidity. For practical purposes, this data is similar to the DIN 6271 and BS 5514 standards, with the difference that the fuel has a density of 840 g/litre and a lower energy value is 42,700 kJ/kg.

Propeller shaft power according to ISO 8665

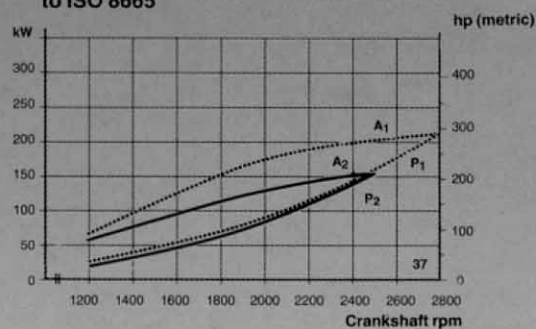

Propeller shaft power curves according to ISO 8665.
A1 = application PD/LD
A2 = application MD

Calculated propeller load curves for fixed propellers.
P1 = exponent 2.5 (planing boats)
P2 = exponent 2.7 (semi-planing boats)

Fuel consumption diagram

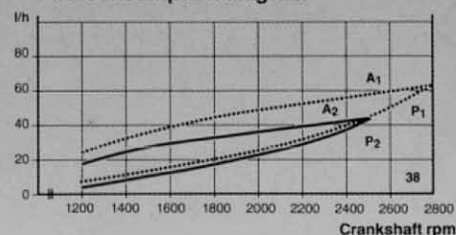

The curves in the fuel consumption diagram correspond to the power curves in the power output diagram.

Dimensions

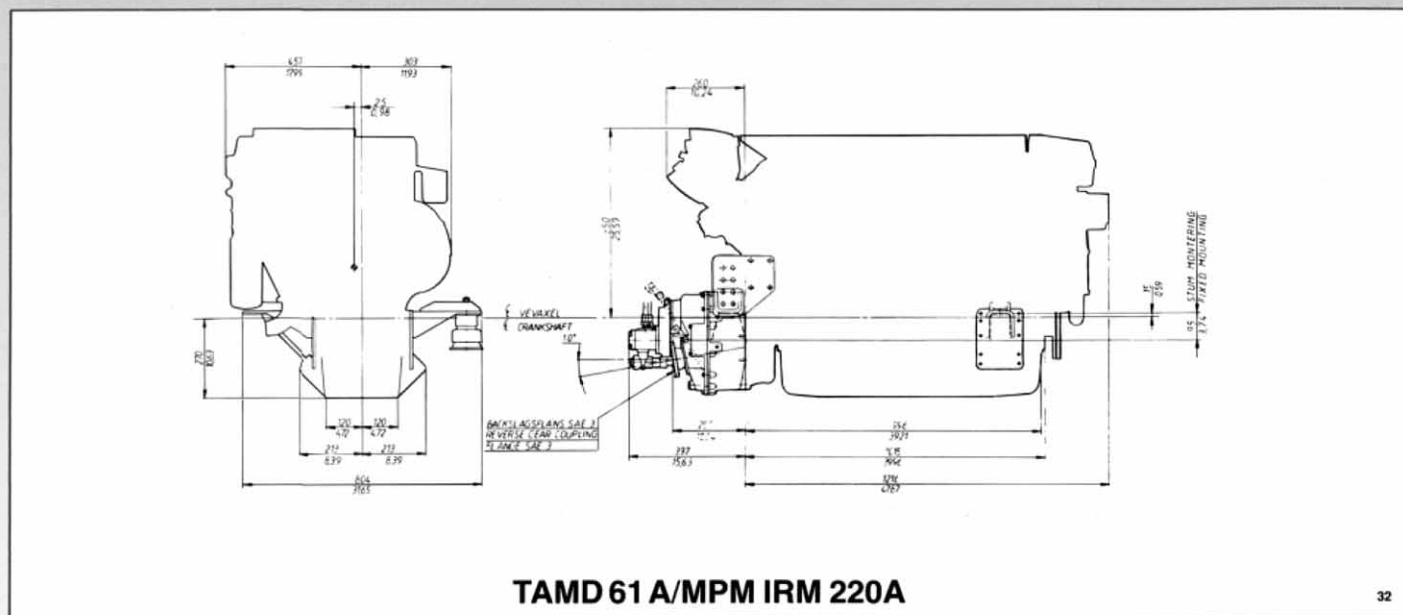

TAMD 61 A/MPM IRM 220A