

# TD 730 VE

Engine for industrial applications

**TD 730 VE**

Turbocharged  
 Diesel fuel  
 Displacement indication (l)  
 Generation  
 Version  
 Versatility engine  
 Emission controlled

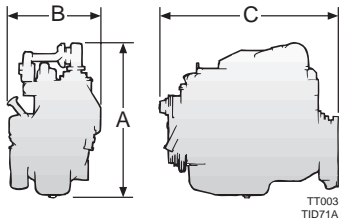

A = 1110 mm / 43.7 in.  
 B = 626 mm / 24.6 in.  
 C = 1265 mm / 49.8 in.

- Based on Volvo's well proven, dependable six-in-line turbocharged engine.
- Built with a high degree of precision to withstand high outputs and at the same time correspond to high demands on operational safety and service life.
- Exhaust gas emission controlled.
- Smoke control through effective smoke limiter.

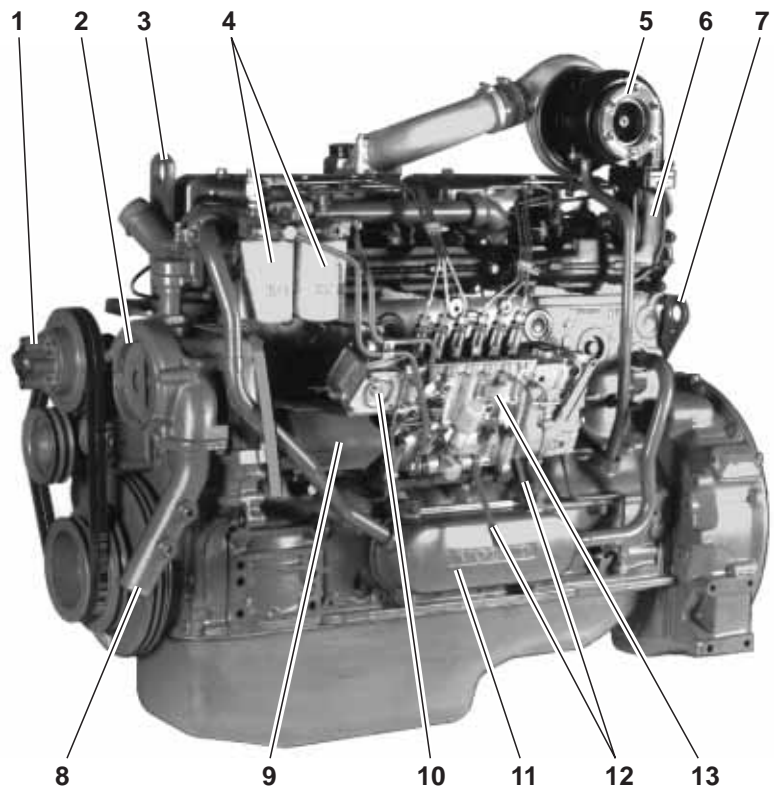

1. Fan hub
2. Gear-driven coolant pump
3. Lift eyelet
4. Twin fuel filters of throw-away type
5. Turbocharger
6. Air cooled exhaust manifold
7. Lift eyelet
8. Coolant pipe, inlet
9. Pump coupling guard
10. Smoke limiter
11. Oil cooler
12. Fuel pipes for tank connection
13. Injection pump
14. Relay for inlet manifold heater
15. Cable iron
16. Lift eyelet
17. Coolant pipe, outlet
18. Flywheel housing SAE 2
19. Starter motor
20. Crankcase ventilation
21. Full-flow oil filter of spin-on type
22. By-pass oil filter of spin-on type
23. Vibration damper
24. Automatic belt tensioner

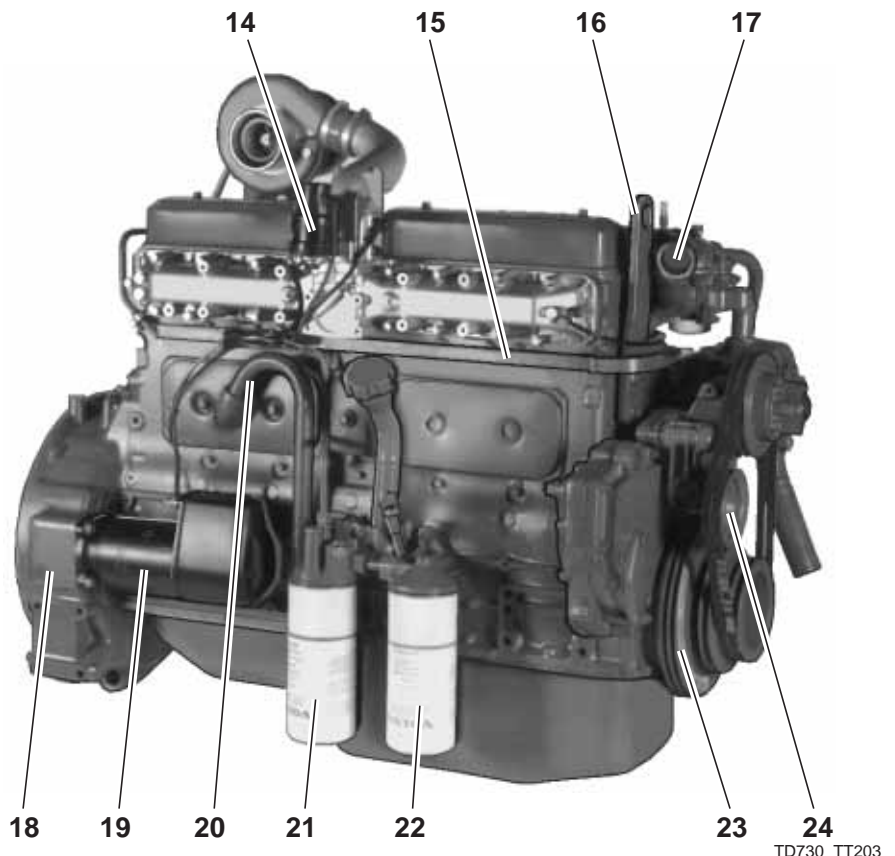

# Technical data TD 730VE

Volvo Penta reserves the right to make changes at any time, without notice, as to technical data, prices, materials, standard equipment, specifications and models, and to discontinue models.

## General

In-line four-stroke diesel engine with direct injection

Turbocharged		Bore	104.77 mm / 4.12 in
Number of cylinders	6	Stroke	130 mm / 5.12 in
Displacement, total	6.73 liters / 411 in <sup>3</sup>	Compression ratio	17.7:1

Firing order	1-5-3-6-2-4	Dry weight	760 kg / 1676 lb
Rotation direction, anti-clockwise viewed towards flywheel		Wet weight	802 kg / 1768 lb

TD 730 VE	Speed, rpm	1800	2000	2200	2400
Performance	Test no.	29000832			
IFN Power					
without fan	kW / hp	142 / 193	147 / 200	150 / 204	150 / 204
with fan	kW / hp	138 / 188	142 / 193	143 / 195	141 / 192
ICFN Power					
without fan	kW / hp	129 / 175	134 / 182	136 / 185	136 / 185
with fan	kW / hp	125 / 170	129 / 175	129 / 175	127 / 173
Torque at					
IFN Power	Nm / lbft	753 / 556	702 / 518	651 / 480	597 / 440
ICFN Power	Nm / lbft	684 / 505	640 / 472	590 / 435	541 / 399
Mean piston speed	m/s / ft/sec	7.8 / 25.6	8.7 / 28.5	9.5 / 31.2	10.4 / 34.1
Effective mean pressure at ICFN Power	MPa / psi	1.41 / 204	1.31 / 190	1.21 / 175	1.16 / 168
Max combustion pressure at ICFN Power	MPa / psi	11.4 / 1653	12.2 / 1770	12.9 / 1870	13.3 / 1930
Total mass moment of inertia, J (mR <sup>2</sup> )	kgm <sup>2</sup> / lbft <sup>2</sup>	1.63 / 38.67			
Degree of irregularity at IFN Power		1:131	1:225	1:390	1:505
Residual speed droop					
at load increase from 0 to 100% at IFN Power	%				6-8
Friction Power	kW	24	28	31	37

## Lubrication system

Lubricating oil average consumption at

ICFN Power	g/kwh	0.30
Oil system capacity including filters	liters	29
Oil change interval		
VDS-2	h	600
VDS	h	400
CCMC D5	h	200

## Fuel system

Specific fuel consumption at

25% of IFN Power	g/kWh / lb/hph	264 / 0.428	282 / 0.457	307 / 0.497	333 / 0.539
50% of IFN Power	g/kWh / lb/hph	230 / 0.373	240 / 0.389	254 / 0.412	274 / 0.444
75% of IFN Power	g/kWh / lb/hph	217 / 0.352	225 / 0.365	235 / 0.381	250 / 0.405
100% of IFN Power	g/kWh / lb/hph	216 / 0.350	223 / 0.361	233 / 0.378	246 / 0.398

## Intake and exhaust system

Air consumption at IFN Power	m <sup>3</sup> / min / cfm	11.4 / 402	13.1 / 463	14.8 / 522	16.1 / 568
Max allowable air intake restriction	kPa / In wc		5 / 20		
Heat rejection to exhaust at IFN Power	kW / BTU/min	141 / 8020	152 / 8645	165 / 9380	180 / 10240
Exhaust gas temperature after turbine at IFN Power	°C / °F	515 / 960	495 / 925	480 / 895	480 / 895
Max allowable back-pressure in exhaust line	kPa / In wc	4.8 / 19.3	6.7 / 26.9	8.5 / 34.1	10.0 / 40.0
Exhaust gas flow at IFN Power	m <sup>3</sup> /min / cfm	30.6 / 1080	33.7 / 1191	36.8 / 1300	39.3 / 1390
Exhaust gas smoke	Bosch units	0.4	0.3	0.4	0.4

## Cooling system

Heat rejection radiation from engine at

IFN Power	kW / BTU/min	9 / 510	9 / 510	9.5 / 540	10 / 570
Heat rejection to coolant at IFN Power	kW / BTU/min	88 / 5005	97 / 5515	106 / 6030	116 / 6600

## Power Standards

The engine performance corresponds to ISO 3046, BS 5514 and DIN 6271. The technical data applies to an engine without cooling fan and operating on a fuel with calorific value of 42.7 MJ/kg (18360 BTU/lb) and a density of 0.84 kg/litre (7.01 lb/US gal, 8.42 lb/imp gal), also where this involves a deviation from the standards.

## Rating Guidelines

**IFN Power** rating corresponds to ISO Overload Power. It is intended for applications where intermittent power is utilized less than 1 hour within any period of 12 hours of continuous operation. The average load factor must not exceed the continuous rating.

**ICFN Power** rating corresponds to ISO Standard Power for continuous operation. It is intended for constant load applications with uninterrupted service at full load for extended periods of time.