

DATE	REV	DESCRIPTION	BY	CHKD	DATE
0-14100-00	L3	A: 82.6 (3.25)			01-06-15
0-14100-00	MS	A: CENTER OF GRAVITY			01-06-15
0-14100-00	MS	A: 285.69 (18.37)			01-06-15
0-14100-00	L5	A: 120.75 (7.5)			01-06-15
0-14100-00	A2	INSTALLATION DRAWING GENV V8			01-06-15
		INSTALLATION DRAWING V8			

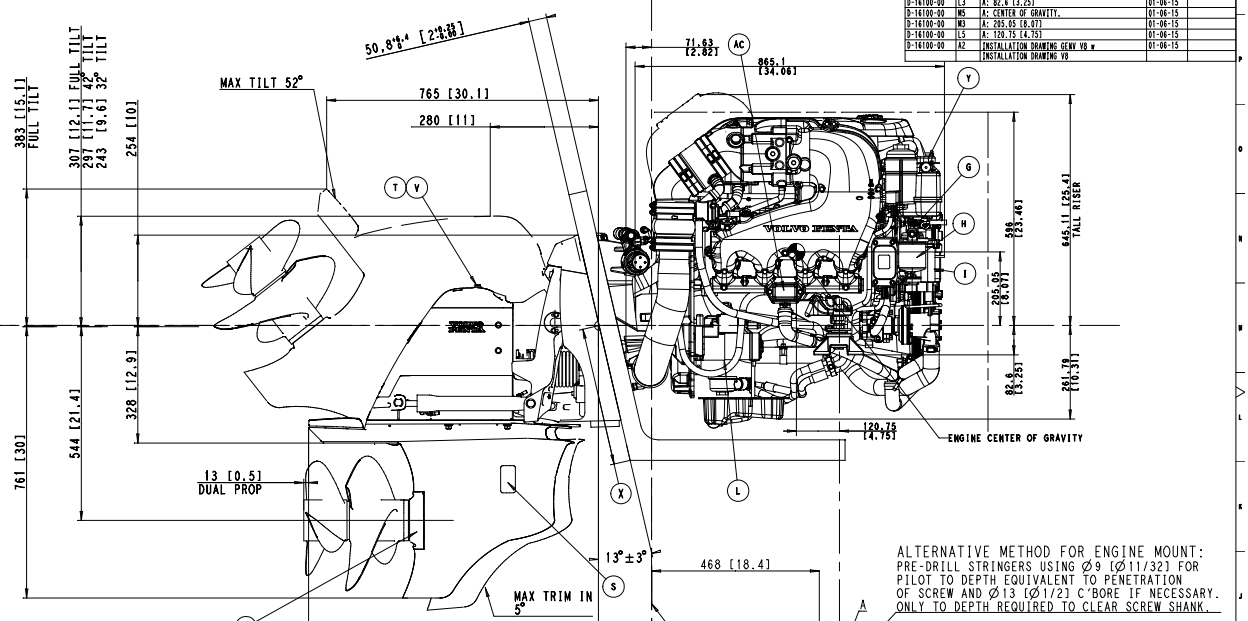

LETTER	NAME
A	OIL FILTER, ENGINE
B	OIL FILL, ENGINE
C	OIL DRAIN, ENGINE
D	OIL DIPSTICK, ENGINE
E	RAW WATER DRAIN
F	LIFTING DEVICE
G	FUEL CONNECTION, I.D. 9.5 (3/8) NPT OR 6.35 (1/4) NPT
H	FUEL FILTER
I	ELECTRICAL FUEL PUMP
J	THROTTLE CABLE SINGLE
K	WATER COOLED EXHAUST PIPE FOR HOSE I.D. 98.4 (3 7/8")
L	STARTER MOTOR
M	FUSE PANEL
N	ELECTRICAL CONNECTION ENGINE - INSTRUMENT PANEL
O	CIRCUIT BREAKER FOR TRIM PUMP
P	OIL FILL, POWER STEERING
R	STEERING CABLE
S	WATER INTAKE
T	OIL FILL, OUTBOARD UNIT
U	OIL DRAIN, OUTBOARD UNIT
V	OIL DIPSTICK, OUTBOARD UNIT
X	SEE INSTALLATION INSTRUCTIONS
Y	COOLANT FILL AND LEVEL CHECK
Z	ENGINE FLUSH
AC	ANODE, EXHAUST MANIFOLDS (BOTH SIDES)

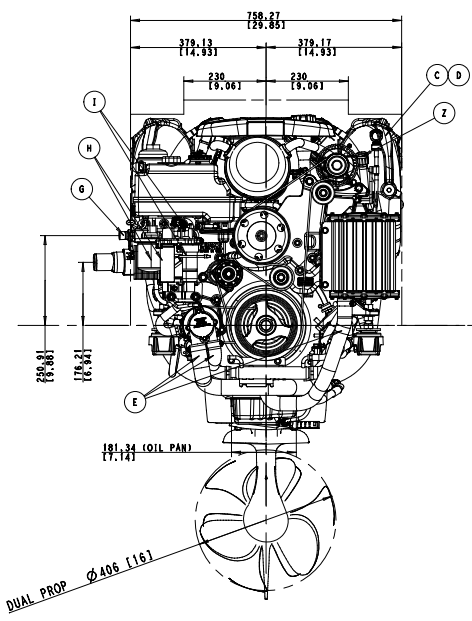
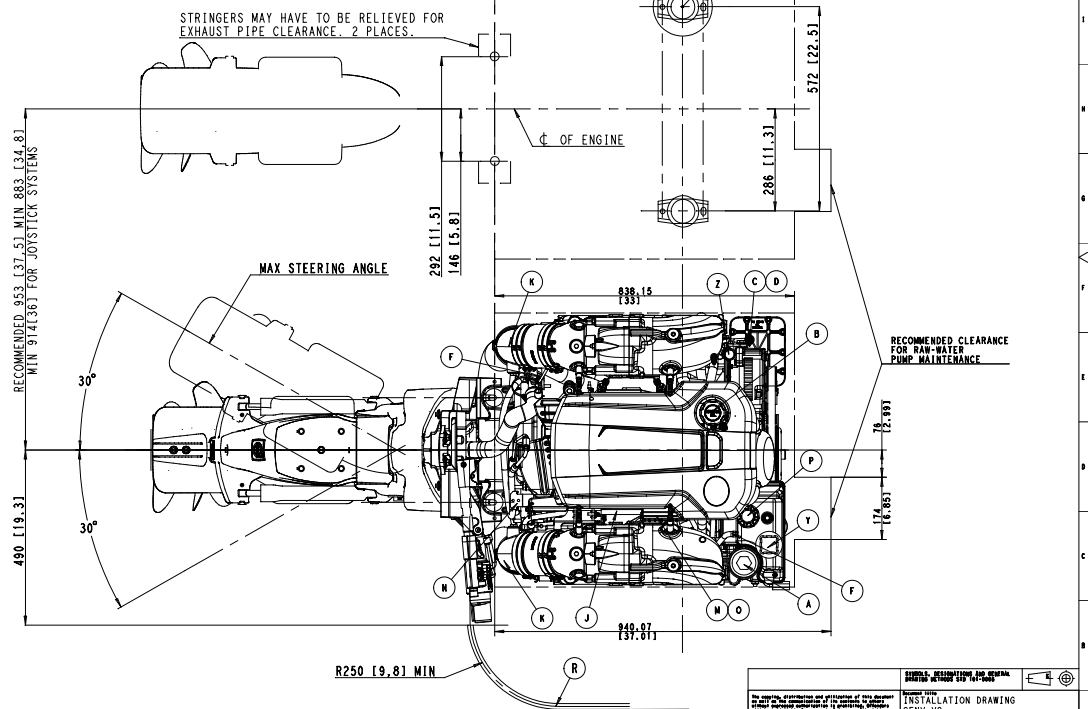
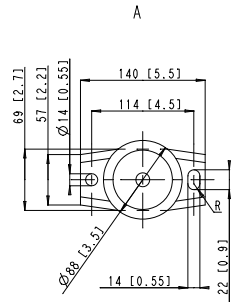

INSTALLATION DRAWING  
GENV V8

22534187

102

1113