

V8-380/DPS



Technical Data

Engine designation	V8-380-C
Horsepower, kW (hp)	279 (380)
Engine speed, rpm	6000
Displacement, l (in ³)	6.0 (364)
Number of cylinders	V8
Bore/stroke, mm (in.)	101.6/91.9 (4.00/3.62)
Compression ratio	9.67:1
Fuel system	Multi-Port Injection
Volvo Penta Duoprop drive	DPS
Ratio	1.95:1, 2.14:1, 2.32:1
Dry weight with DP, incl. prop. & PS, kg (lb)	506 (1115)
Rating	R5*
The engine complies with	US EPA, CARB, EU RCD

Horsepower according to ISO 8665

* RATING 5, for pleasure craft applications

V8-380/DPS

Technical description:

Engine block and head

- Deep skirt cylinder block with six bolt, powdered metal main caps for extra strength
- High flow aluminum cylinder heads
- Increased compression ratio for better thermal efficiency
- Hydraulic cam phaser for variable camshaft timing optimizes low end torque and high-end horse power
- Floating piston pins for reduced noise and increased durability
- Steel camshaft and roller rocker arms for decreased friction and greater reliability
- Inconel exhaust valves for prolonged life

Lubrication system

- Pressure lubrication system with heavy duty engine oil cooler and remote oil filter
- Paper oil filter element reduces environmental impact of engine service

Electronic engine control

- Electronic Control Module (ECM) ensures constant, optimum performance, greater fuel efficiency and reduced emissions
- 4G ECM supports full diagnostics through connection on engine harness
- Closed loop system with pre- and post catalyst oxygen sensors helps control fuel delivery and reduce emissions

Fuel system

- Multi-Port Fuel Injection system
- Vapor separating fuel pump system with two electric pumps, pressure regulator, and water separating fuel filter

Intake and exhaust system

- Low weight aluminum exhaust system
- Exhaust passages optimized for torque and power
- Manifolds cooled by engine coolant as part of the standard freshwater cooling system
- Collector (elbow) design maximizes use of the catalyst for reduced back pressure
- 3 inch riser option is a direct replacement for the standard height elbow

Cooling system

- Full freshwater (closed) cooling system for engine, exhaust manifolds, engine oil cooler
- Advanced Volvo VCS (yellow) coolant for superior corrosion and thermal protection

Electrical system

- 12V corrosion-protected electrical system
- 75A marine alternator with internal transistorized voltage regulator
- Re-settable circuit breaker for trim system
- Fuse protection of the fuel pumps and the fuel injection system

Available instruments

(optional in some markets)

- Complete instrument panel including:

Tachometer, temperature gauge, oil pressure gauge, voltmeter, key switch, two fuses, instrument light switch

- Wiring harness from engine to instrument panel
- Control switch for power trim
- Wiring harness from trim pump to switch for power trim and trim gauge

Drive

- Cone clutch for smoother shifting
- Pattern-matched spiral bevel gears
- Exhaust through propeller hub, cavitation plate
- Break-away coupling between vertical shafts
- Standard tilt specification 52° (42° and 32° available as option on engine order)
- The drive can be turned 28° in each direction
- Built-in kick-up function to reduce damage, in the event the drive strikes an underwater object
- Easy access drive and transom shield anodes
- Optional electronic steering – prerequisite for Sterndrive Joystick, twin installation only

Power trim

- High capacity trim pump integrated with transom shield to ease installation and save space in engine compartment

Dimensions V8-380/DPS

Not for installation

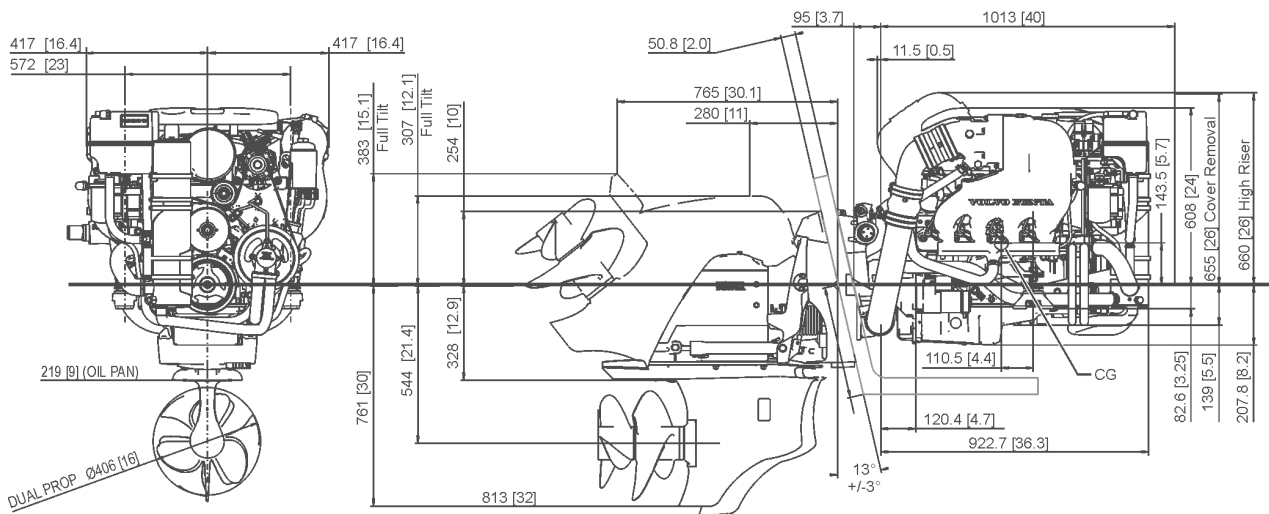

More information

Contact your nearest Volvo Penta dealer for more information about Volvo Penta engines and optional equipment/accessories or go to www.volvopenta.com



IOS



Android

Download the Volvo Penta dealer locator App for your iPhone or Android

VOLVO PENTA

AB Volvo Penta

SE-405 08 Göteborg, Sweden
www.volvopenta.com

Not all models, standard equipment and accessories are available in all countries. All specifications are subject to change without notice. The engine illustrated may not be entirely identical to production standard engines.